

SONANCE LANDSCAPE SERIES

LS12ESUB IN-GROUND SUBWOOFER



Product Family Overview

The LS12ESUB is the second generation of the 70 Volt Sonance Landscape Series in-ground subwoofer. The LS12ESUB is the perfect partner for the LS68SAT, delivering higher quality sonic performance and higher SPL that is scalable for even the largest space. The SLS SAT & SUB system provides a superior landscape aesthetic enabling

camouflaged speakers to evenly immerse a space with extraordinary stereo sonic performance in any terrain. The robust professional-grade drivers and electronics coupled with our proprietary Ultra-Violet (UV) resistant composite enclosures ensure years of enjoyment. 70 Volt systems allow for extremely flexible and expandable landscape designs.

Features and Benefits

- Part of a scalable system that delivers perfectly even coverage and unequalled sonic performance throughout any sized space
- Below-ground subwoofer provides superior bass while seamlessly blending into the landscape environment
- Robust construction designed to handle the most extreme conditions
- Tuned port / deep, powerful, tight bass
- 12" woofer
- 300 Watt transformer
- Front-firing band-pass design
- 1/2" thick (LDPE) non-corrosive sealed enclosure
- 70 Volt systems allow expandable landscape designs



Dimensions

LSV12ESUB

Overall

Length: 34 13/16" (884mm)

Height: 29 25/32" (756mm)

Woofer Enclosure

Length: 19 3/4" (502mm)

Diameter: 14" (355mm)

Canopy

Height: 7" (178mm)

Diameter: 13 29/32" (353mm)

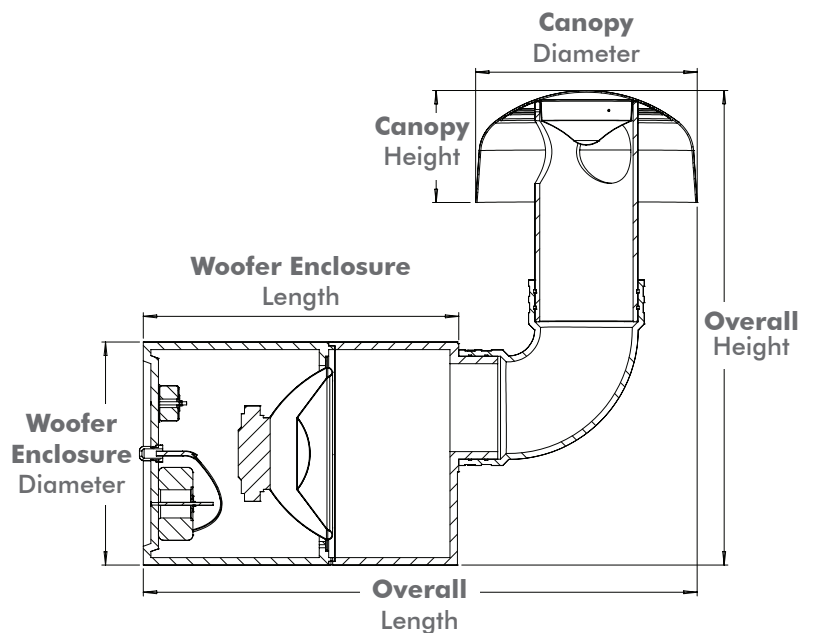

Specifications



SPECIFICATIONS

LS12ESUB

SKU	93110
UOM	Each
Woofers	12" (305mm) polypropylene cone with a Santoprene rubber surround
Frequency Response	25Hz – 100Hz ±3dB
Transformer	70V/300 Watts
Enclosure Material	1/2" (LDPE) non-corrosive black Rotomould sealed enclosure
Finish	Black enclosure, dark brown textured canopy
Dimensions (L x H) or (L or H x Dia.)	Overall Dimensions: 34 13/16" L x 29 25/32" H (884mm x 756mm) Woofers Enclosure: 19 3/4" L x 14" Dia. (502mm x 355mm) Canopy: 7" H x 13 29/32" Dia. (178mm x 353mm)
Shipping Weight	Subwoofer: 44 lbs (20 kg) Elbow & Canopy: 19 lbs (8.6 kg)



LS12ESUB Associated Products

Sonamp DSP 2-750 Amplifier 93095 
(Each)

LS68SAT 93105 
(Each)

LIMITED FIVE (5) YEAR WARRANTY

Sonance warrants to the first end-user purchaser that this Sonance-brand product ("Product"), when purchased from an authorized Sonance Dealer/Distributor, will be free from defective workmanship and materials for the period stated below. Sonance will at its option and expense during the warranty period, either repair the defect or replace the Product with a new or remanufactured Product or a reasonable equivalent. Warranty Period for this Product: Five (5) years from the date on the original sales receipt or invoice or other satisfactory proof of purchase.



©2015 Sonance. All rights reserved.
Sonance, is a registered trademarks of Dana Innovations.

Due to continuous product improvement, all features and specifications are subject to change without notice.
For the latest Sonance product specification information visit our website: www.sonance.com

SONANCE • 212 Avenida Fabricante • San Clemente, CA 92672-7531 USA
(949) 492-7777 • FAX: (949) 361-5151
www.sonance