

# SONANCE LANDSCAPE SERIES

## LS68SAT TWO-WAY LOUDSPEAKER



### Product Family Overview

The LS68SAT is the second generation of the 70 Volt Sonance Landscape Series satellite loudspeaker. The SLS SAT & SUB system provides a superior landscape aesthetic enabling camouflaged speakers to evenly immerse a space with extraordinary sonic performance in any terrain. The LS68SAT can be positioned in trees,

hidden in planting beds, or along walkways. The robust professional-grade drivers and electronics coupled with our proprietary Ultra-Violet (UV) resistant composite enclosures ensure years of enjoyment. 70 Volt audio systems allow for extremely flexible and expandable landscape designs.

### Features and Benefits

- Part of a scalable system that delivers perfectly even coverage and unequalled sonic performance throughout any sized space
- Designed to be hidden under plants and in trees
- Two-way loudspeaker for detail & clarity
- Color-molded composite construction won't chip, peel or fade over time
- (UV) resistant composite enclosure
- 1/2" NPS male mounting threads enable various mounting options
- Robust construction designed to handle extreme conditions
- Rust-proof protective grille
- 50 Watt transformer
- 70 Volt systems allow expandable landscape designs



### Dimensions

#### LS68SAT

Length: 10 3/16" (258mm)

Diameter: 6 21/32" (169mm)

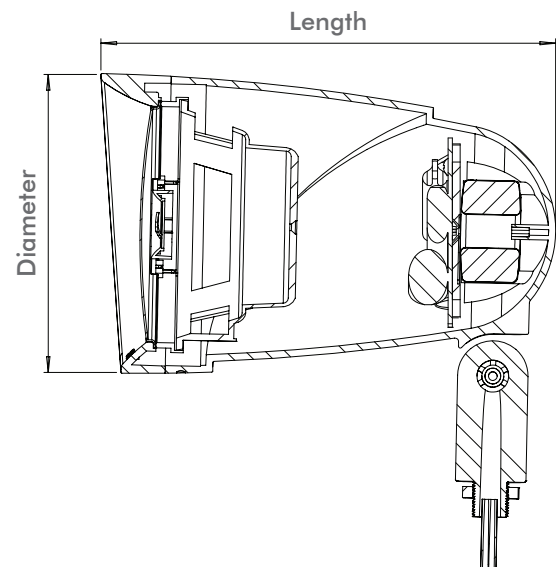

## Specifications





### SPECIFICATIONS

### LS68SAT

SKU	93105
UOM	Each
Tweeter	1/2" (13mm) PEI dome
Woofers	6" (152mm) polypropylene cone with a Santoprene rubber surround
Frequency Response	60Hz - 20kHz $\pm$ 3dB
Transformer	70V/50 Watts
Enclosure Material	Non-corrosive sealed enclosure
Listening Area	60° coverage, 10' to 60' recommended
Dimensions (L x Dia.)	10 3/16" x 6 21/32" (258mm x 169mm)
Shipping Weight	7 lbs (3.17 kg)



## LS68SAT Associated Products

Sonamp DSP 2-750 Amplifier (Each)	93095	
LSV10SUB (Each)	93104	
LS12ESUB (Each)	93110	

### LIMITED FIVE (5) YEAR WARRANTY

Sonance warrants to the first end-user purchaser that this Sonance-brand product ("Product"), when purchased from an authorized Sonance Dealer/Distributor, will be free from defective workmanship and materials for the period stated below. Sonance will at its option and expense during the warranty period, either repair the defect or replace the Product with a new or remanufactured Product or a reasonable equivalent. Warranty Period for this Product: Five (5) years from the date on the original sales receipt or invoice or other satisfactory proof of purchase.



©2015 Sonance. All rights reserved.  
Sonance, is a registered trademarks of Dana Innovations.

Due to continuous product improvement, all features and specifications are subject to change without notice.  
For the latest Sonance product specification information visit our website: [www.sonance.com](http://www.sonance.com)

SONANCE • 212 Avenida Fabricante • San Clemente, CA 92672-7531 USA  
(949) 492-7777 • FAX: (949) 361-5151  
[www.sonance](http://www.sonance)