

# RSH CUSTOM RACKSHELF

## ASSEMBLY INSTRUCTIONS

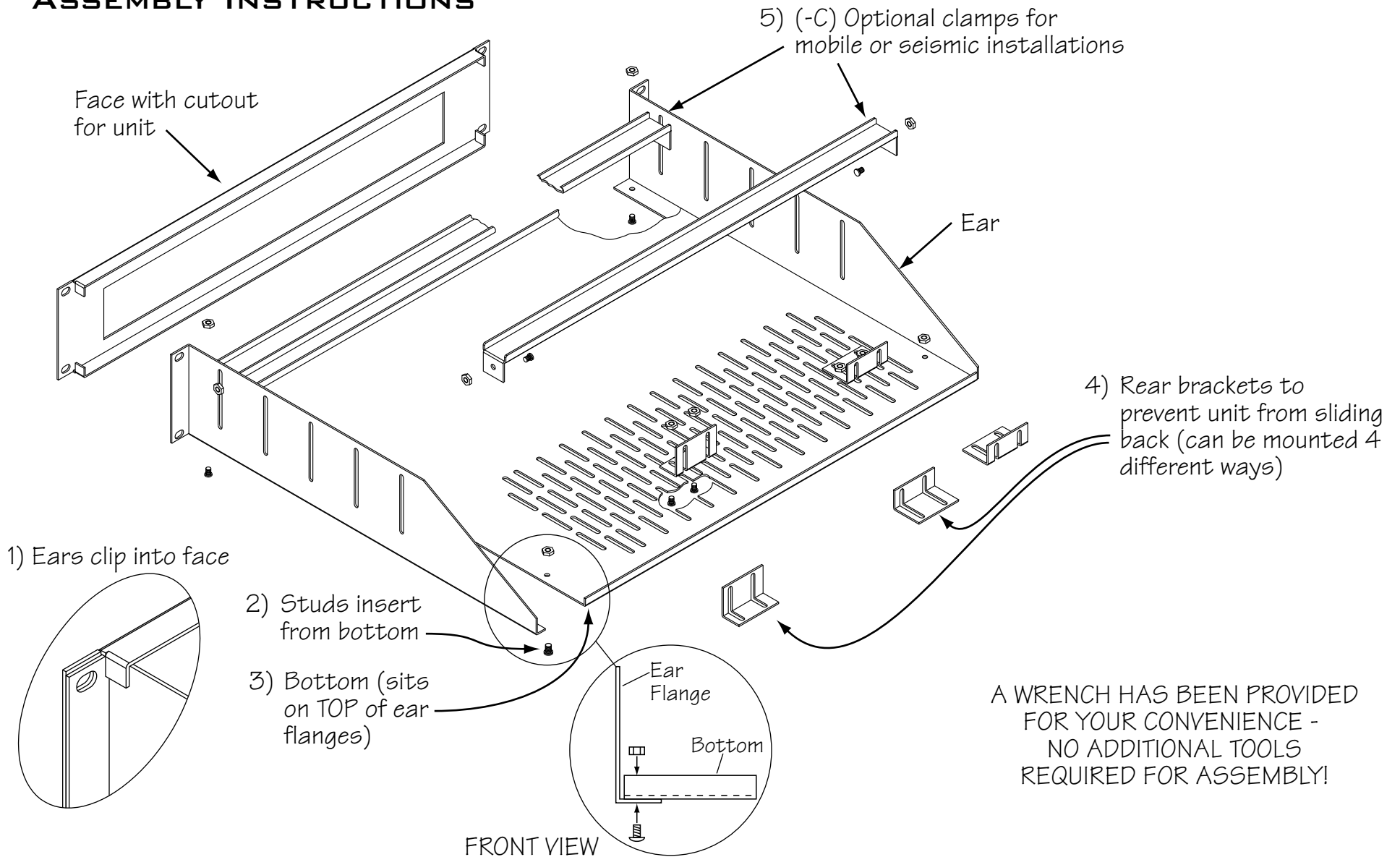

Instruction # <b>I-1505</b>	Rev. <b>G</b>	Date: <b>11/11/03</b>
Part # <b>RSH</b>	Assembly: full	
Page: 1 of 1		
North Corporate Drive Riverdale, NJ 07457	Voice 973-839-1011 Fax 973-839-1976	www.middleatlantic.com



INSTRUCTION # I-1505 REV. G 11-11-03