

Installation Instructions

PD1 & 2 - Projector Drop Mechanism

Design Highlights

- Outputs for 3rd Party Product Control
- Cassette Housing for Ease of Installation
- Full Cable Management
- Tilt Function
- Range of Drop Options



Thank you for choosing
futureautomation

PD1 & 2 - Projector Drop Mechanism



Caution
Warning



Beware of
Moving Parts



Danger
Electricity



Keep Hands
Clear

Safety Disclaimer

Important Safety Instructions

Explanation of graphical symbols

-(Electric Shock Symbol) = The lightning flash within an equilateral triangle is intended to alert you to the presence of un-insulated "dangerous voltage" within the products enclosure that may be of sufficient magnitude to constitute an electric shock to persons

-(Caution Symbol) = The exclamation point within an equilateral triangle is intended to alert you to the presence of important operating and maintenance (servicing) instructions in the literature accompanying the product

-(Tools Symbols) = The tools symbol within a coloured square are intended to highlight the required tools necessary for correct and safe installation of the product. These are intended as a guide only, and it is at the installer's discretion as to which tools are used.

WARNING: RISK OF ELECTRIC SHOCK, ONLY AUTHORIZED INSTALLERS TO OPEN THE POWER CONTROL BOX.

WARNING: To reduce the risk of fire or electric shock, do not expose electrical parts to rain or moisture, unless the product has been specifically designed to do so.

WARNING: Failure to provide adequate structural strengthening, prior to installation can result in serious personal injury or damage to the equipment. It is the installer's responsibility to ensure the structure to which the component is affixed can support the four times the weight of the component.

WARNING: Do not exceed the weight capacity. This can result in serious personal injury or damage to the equipment. It is the installer's responsibility to ensure that the total combined weight of all attached components does not exceed that of the maximum figure stated.

WARNING: Failure to provide adequate structural strength for this component can result in serious personal injury or damage to equipment! It is the installer's responsibility to make sure the structure to which this component is attached can support five times the combined weight of all equipment. Reinforce the structure as required before installing the component.

Warnings:

1. Read all technical instructions fully before installation and use. It is the installer's responsibility to ensure that all documentation is passed on to the end user and read fully before operation.
2. Keep all documentation.
3. Heed all warnings.
4. Follow all technical specifications and instructions during installation.
5. Do not use near water unless the product has been specifically designed to do so.
6. Clean only with a dry cloth.
7. Do not defeat the purpose of the polarized or grounding type plug. A polarized plug has two blades, one wider than the other. A grounding type plug has two blades and a grounding prong. The wide blade or third prong are provided for your safety. If the provided plug does not fit your outlet, consult an electrician or contact the manufacturer.
8. Protect the power cord from being walked on or pinched, particularly at plugs, convenience receptacles, and the point where the exit from the apparatus.
9. Unplug the apparatus during lightning storms or when unused for long periods of time.
10. Only use attachments/accessories specified by the manufacturer.
11. Refer all servicing to qualified personnel. Servicing is required regularly on an annual basis, when the apparatus is damaged in any way, liquid has been spilled or objects have fallen into the apparatus, the apparatus has been exposed to rain or moisture, does not operate normally, or has been dropped.
12. To completely disconnect the apparatus from the AC mains, disconnect the power cord plug from the AC receptacle on the power control box.
13. To prevent overheating, do not cover the apparatus. Install in accordance with the instructions.
14. UK, Ireland and Hong Kong only – The power cord is supplied with a 13A plug having an earthing pin. The apparatus is earthed and this pin is not required for safety, merely to operate the safety shutter of mains outlet.
15. No naked flames such as lit candles should be placed on the unit.
16. Observe and follow the local regulations when disposing of batteries.
17. Do not expose the unit to dripping or splashing fluids.
18. Do not place objects filled with liquid, such as vases, on the unit.
19. Do not expose the batteries to excessive heat such as sunshine, fire or the like.
20. For all mounted apparatus, the apparatus should be installed on solid wood, bricks, concrete or solid wood columns and battens.
21. Always turn off power at source before putting on or taking off parts and cleaning.
22. Do not use outdoors unless marked for outdoor use.
23. Exceeding the weight capacity can result in serious personal injury or damage to equipment.

Future Sound & Vision trading as Future Automation intend to make this and all documentation as accurate as possible. However, Future Automation makes no claim that the information contained herein covers all details, conditions or variations, nor does it provide for every possible contingency in connection with the installation or use of this product. The information contained in this document is subject to change without prior notice or obligation of any kind. Future Automation makes no representation of warranty, expressed or implied, regarding the information contained herein. Future Automation assumes no responsibility for accuracy, completeness or sufficiency of the information contained in this document.

PD1 & 2 - Projector Drop Mechanism

Contents	Page
Introduction	
Safety Information	1
Contents	2
Contents	3
Tool Indicator Icons	3
Installation	
Parts List	4
Package Contents	4
Stage 1	
Pre-testing	5
Before You Start Check	5
Drop Distances	5
Stage 2	
Creating The Void	6
Installment Of The Unit Into The Ceiling	6
Control Box Set up	6
Stage 3	
Installation Of The Unit Into The Ceiling	7
Stage 4	
Mounting Details	8
Stage 5	
Adjustments Details	9
Altering Drop Distance	9
Stage 6	
Final Checks	10
Electrical Connections	
Electrical Connections In The Control Box	11
Contact Closure	12
Warning Lights	13
RS232	13
Wiring & Control Box Details	13
Operations	14
Remote Control	14
Operation Buttons	14
Changing The Batteries	14
Trouble Shooting	15/16
Technical Overview	17

PD1 & 2 - Projector Drop Mechanism

Tool Indicator Icons

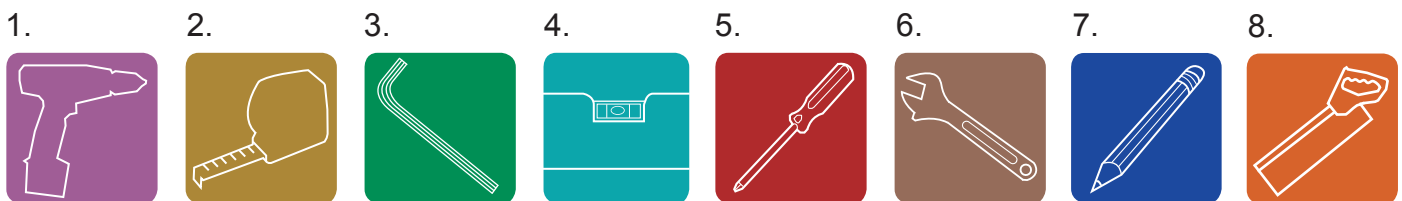

1. - Drill

2. - Tape measure

3. - Allen Keys

4. - Spirit Level

5. - Screwdrivers

6. - Spanners

7. - Pencil

8. - Saw

Product Warranty

This product carries a warranty that covers the cost of labour and spare parts incurred by any defects in materials and workmanship under normal use during a two year period from date of purchase. Support for any problems that are not hardware faults are excluded from the warranty entitlement. This warranty does not affect your statutory consumer rights.

The following is excluded from warranty service:

- Malfunctioning caused by misuse or damage, accidental or otherwise, or service modification by persons not authorised by Future Automation, or the use of any non Future Automation supplied parts;
- Any electrical, or other environmental work external to your Future Automation mechanism including power cuts, surges or lightning strikes;
- Additional items not supplied by Future Automation although they may have been supplied together by the retailer;
- Any 3rd party software products controlling your mechanism;
- Any transfer of ownership. Warranty is provided only to the initial purchaser;
- Compensation for loss of use of the product, and consequential loss of any kind;
- Use of the product over the specified weight capacity;
- Any damage to products during transit that is not checked and notified as "unchecked" or "damaged" upon receipt of delivery.

Any part of your system that needs to be replaced during a warranty repair becomes the property of Future Automation.

PD1 & 2 - Projector Drop Mechanism

Package Contents

- 1 - Mechanism
- 1.1 - Base Plate
- 1.2 - Projector Carriage
- 1.3 - Main Box Ceiling Lip
- 1.4 - Main Box
- 1.5 - Cable Track
- 1.6 - Scissor Arms
- 1.7 - Slider Channel
- 1.8 - Top Cover Lid
- 2 - Control Box
- 3 - IR Remote Control

Not Shown On Page

- 4 - x2 AAA Batteries
- 5 - Multi Pack Of Nuts, Bolts & Washers
- 6 - Mains Power & Other Leads

Nuts & Bolts Multipack:

- Qty. 8 - 40OD x 3mm White plastic washer
- Qty. 4 - M6 Penny washer
- Qty. 4 - 15OD x 6ID x 15mm White plastic spacer
- Qty. 4 - M6 x 20mm Button head bolt
- Qty. 4 - M6 x 35mm Button head bolt
- Qty. 4 - M5 x 20mm Button head bolt

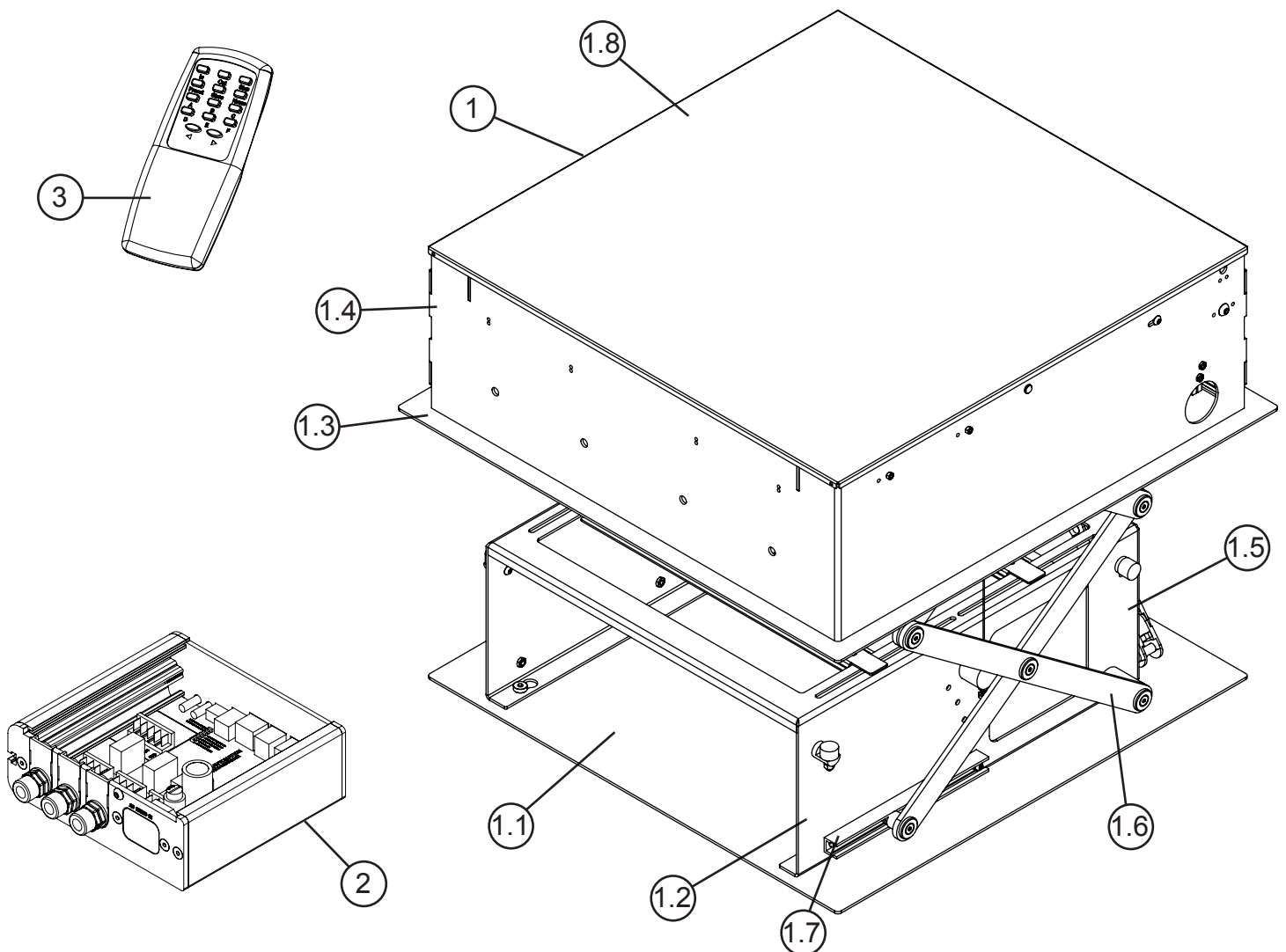

PD1 & 2 - Projector Drop Mechanism

Pre-testing

Before you start check, check the following:

- The product is in good condition
- No damage to any parts
- Wiring is all secure
- The unit is in the closed position
- Test the mechanism, requires 2 people
- See page 15 for remote operations

Do not test the unit when it is sitting on the floor!



Cables will unravel and get tangled if the projector drops
Suspend the unit so the cables can lower the projector when testing.

Open position

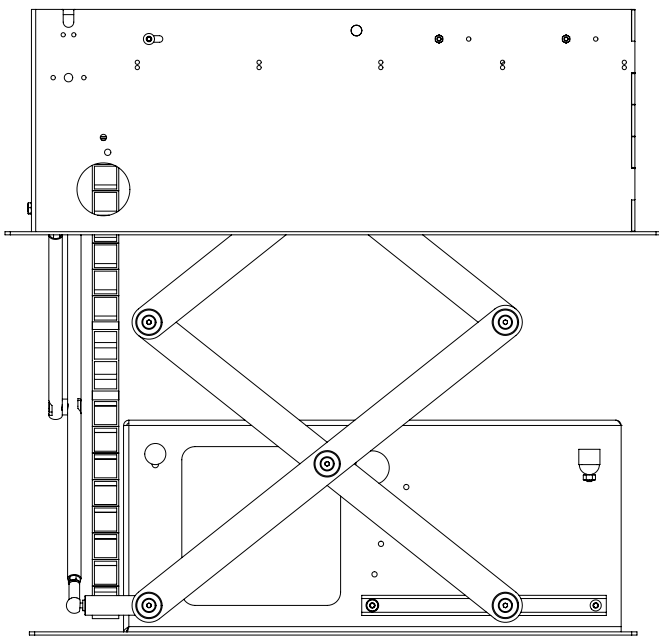

Closed position

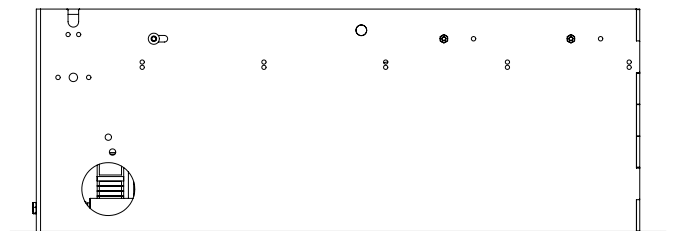

Distance needed below when testing

PD1 & 2 - 400mm [15.7"] Max Drop

PD Extra Drop - 720mm [28.3"] Max Drop

PD Extra Long Drop - 940mm [37"] Max Drop

PD1 & 2 - Projector Drop Mechanism



Creating the void in the ceiling

- Hole size for products: **PD1 - 580mm [22.8"] x 580mm [22.8"]**
PD2 - 630mm [24.8"] x 630mm [24.8"]
- Clear space free from joists and other objects
- Secure timber joists in place to support the unit front and back
- ORGANISE CABLES READY TO THREAD THROUGH THE UNIT

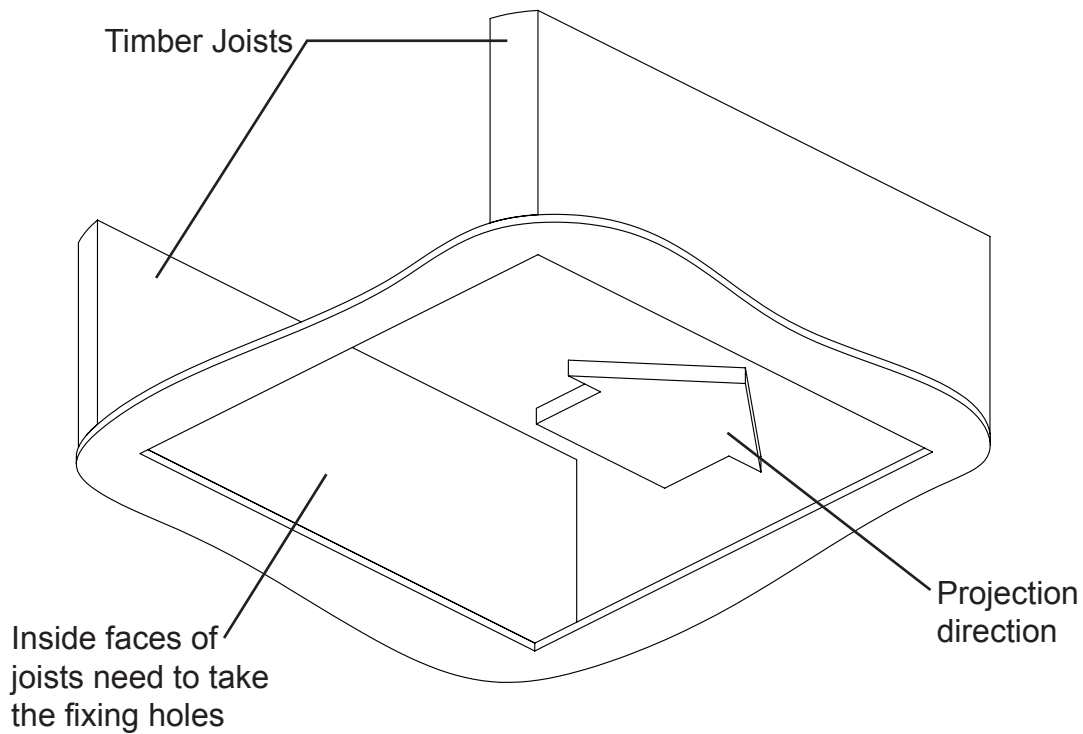

Control box setup

- THE BOX MUST BE EASY TO ACCESS!
- Wire up the control box, refer to page 12 Electrical Connection
- Connect the control box to the mains power supply
- Connect the infrared remote sensor even if you are going to use switch control
- Cables can be easily extended
- There is no manual drop function, access is required for servicing

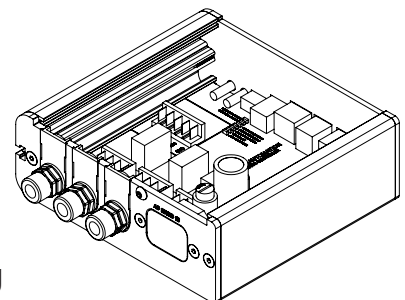

PD1 & 2 - Projector Drop Mechanism



Installation: Stage 3

Installing of the unit into the ceiling

- Remove the base plate by sliding forward then lowering through the key hole details
- ORGANISE THE CABLES READY TO THREAD THROUGH THE CABLE HOLES ON THE SIDE OF THE UNIT! 
- Secure into place using screws through the fixing holes x8
- Check the mechanism and movement of the unit
- Cable management chain can be changed from one side to the other by undoing and mirroring the fixings

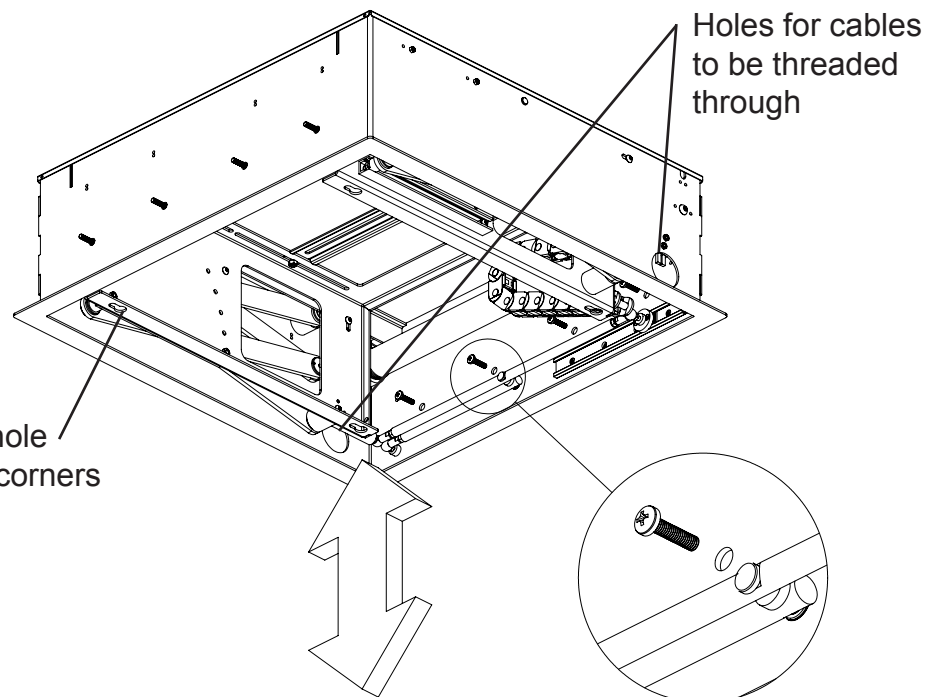
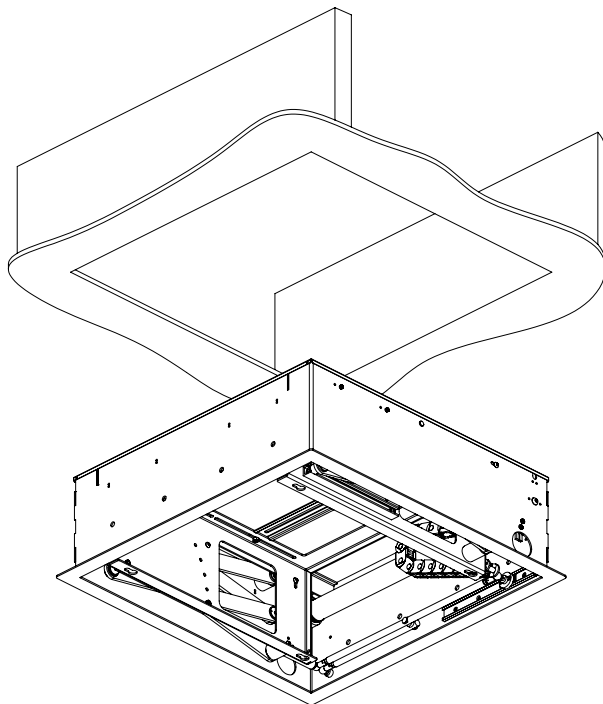
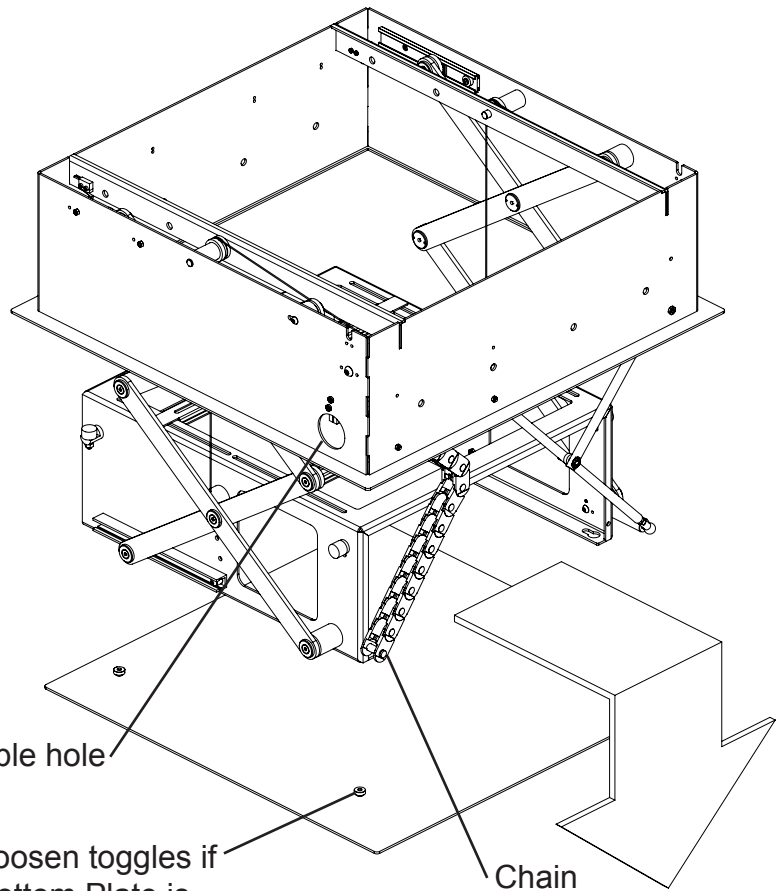

MAKE SURE THE BOTTOM PLATE IS REMOVED SO YOU CAN ACCESS THE FIXING HOLES!

Screw in fixing holes X8

PD1 & 2 - Projector Drop Mechanism



Mounting Details

Check that the projector connects tightly and securely onto the carriage and the Base Plate fits well when operating, Finger tighten screw toggles on Bottom Plate to secure the fixing.

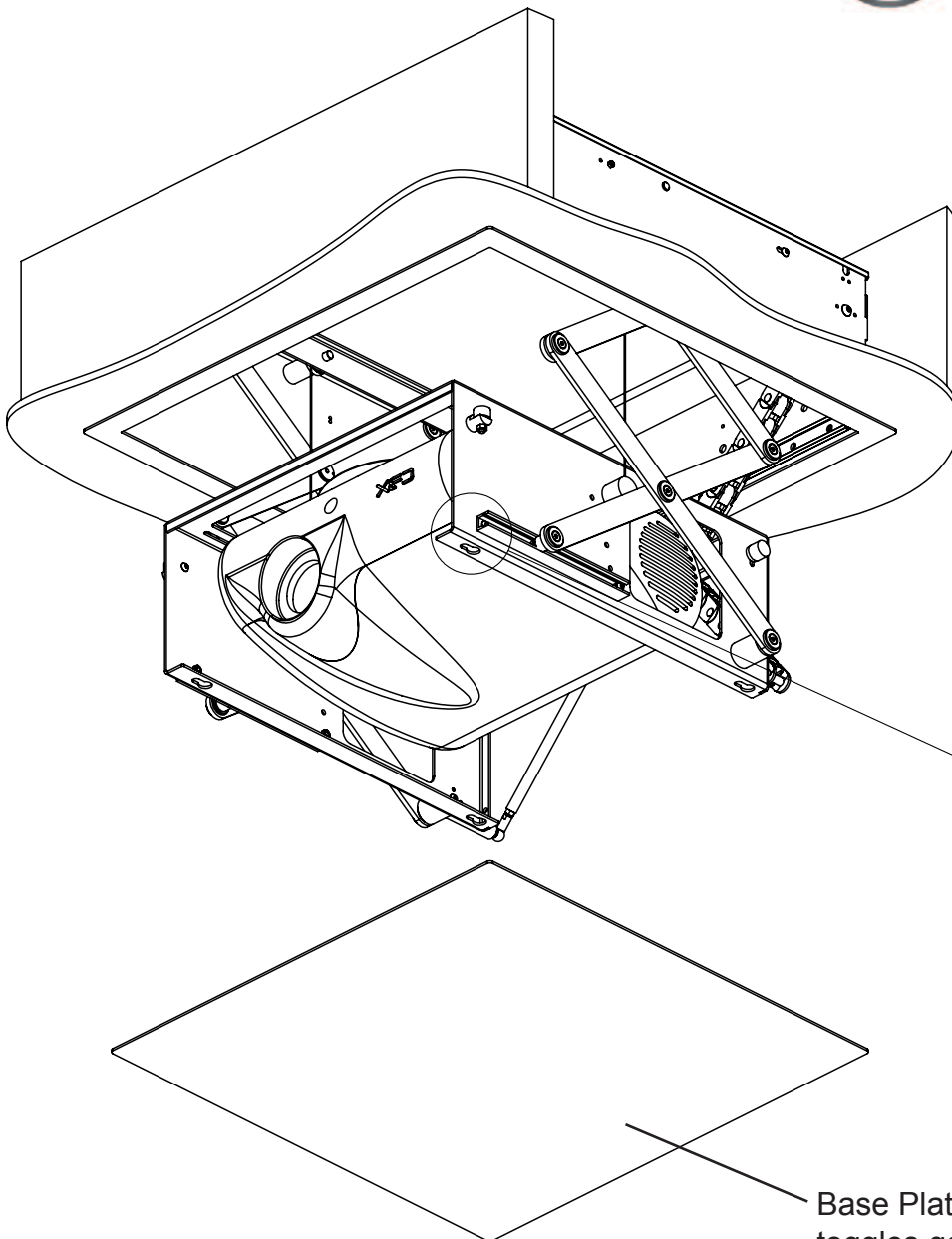
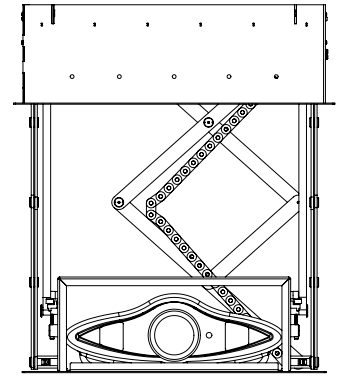
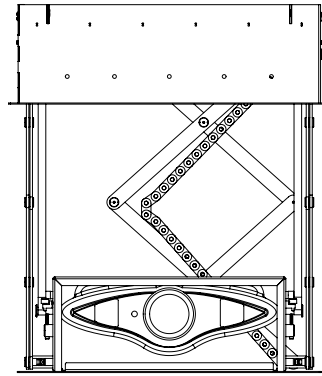

Securely fix the projector to the top surface of the carriage using the range of nuts, bolts & washers provided in the multipack.

Key hole slot detail

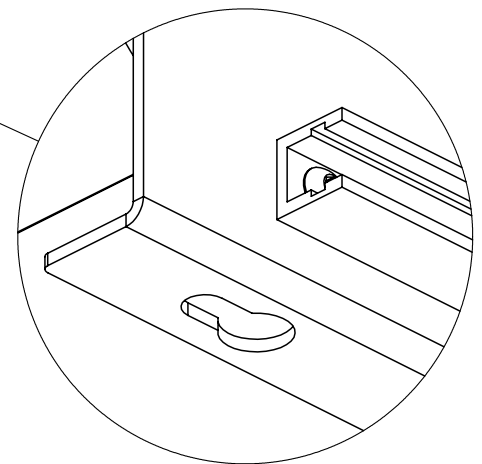

Base Plate slides into place, toggles go through key hole slot detail to lock into place

PD1 & 2 - Projector Drop Mechanism



Adjustments Details

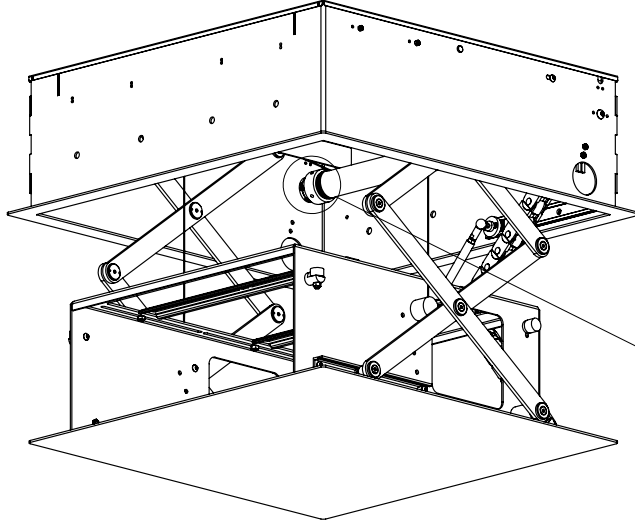

Altering Drop Distance

To change the distance the projector will drop from the ceiling you need to turn the hexagon key marked 2 with a red dot.

- Anti-clockwise
- Lower Position
- Clockwise
- Raise Position

PD's are sent out pre-set to the max drop

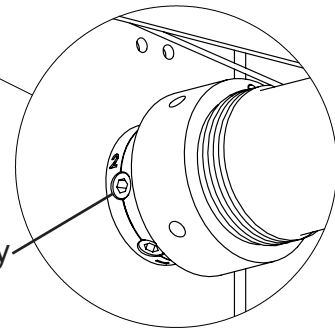

Hexagon Key

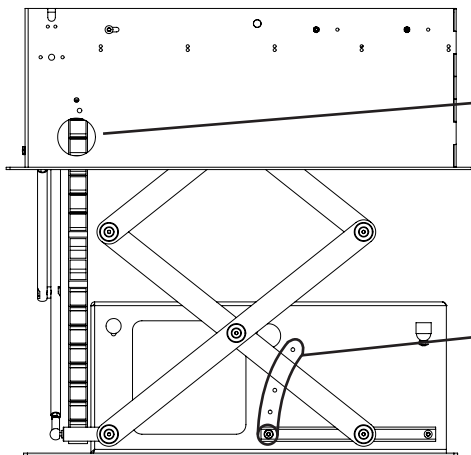

Cable management holes on both sides of the unit.

Locate the side pin into the different holes for alternative angle settings.



Important - When adjusting the drop of the mechanism make sure the sliders in the top of the main box do not reach the stops at the end of the slider channel.

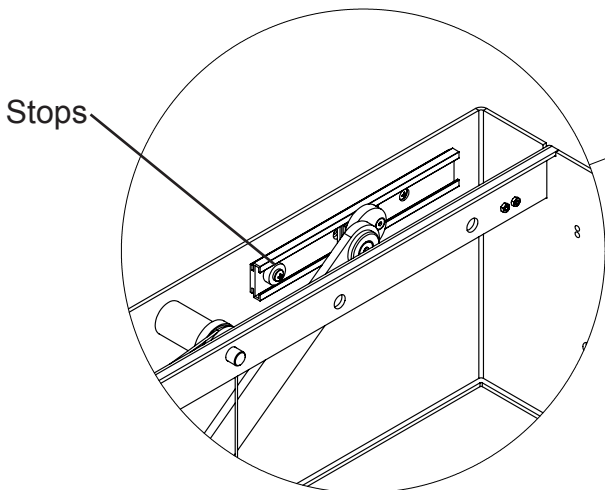

Stops

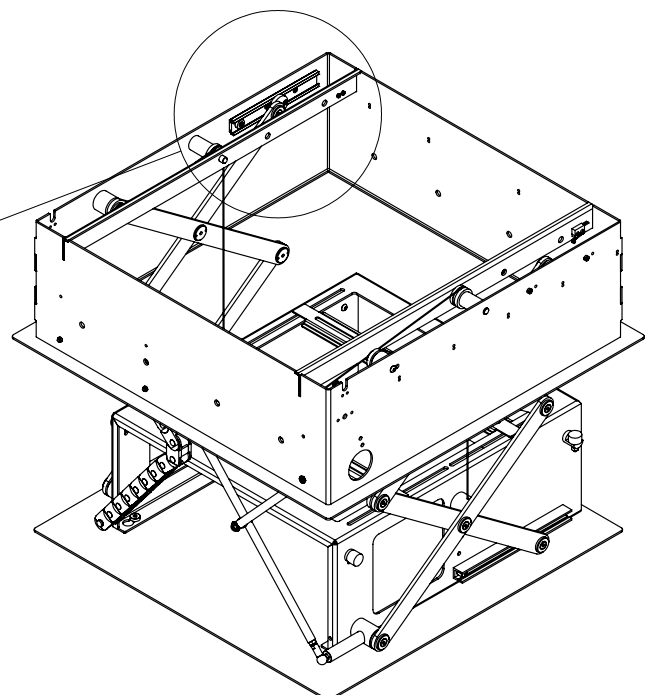

PD1 & 2 - Projector Drop Mechanism



Final checks

- Check the mechanism is working correctly
- Make sure the projector is secure.



Neatly coiled

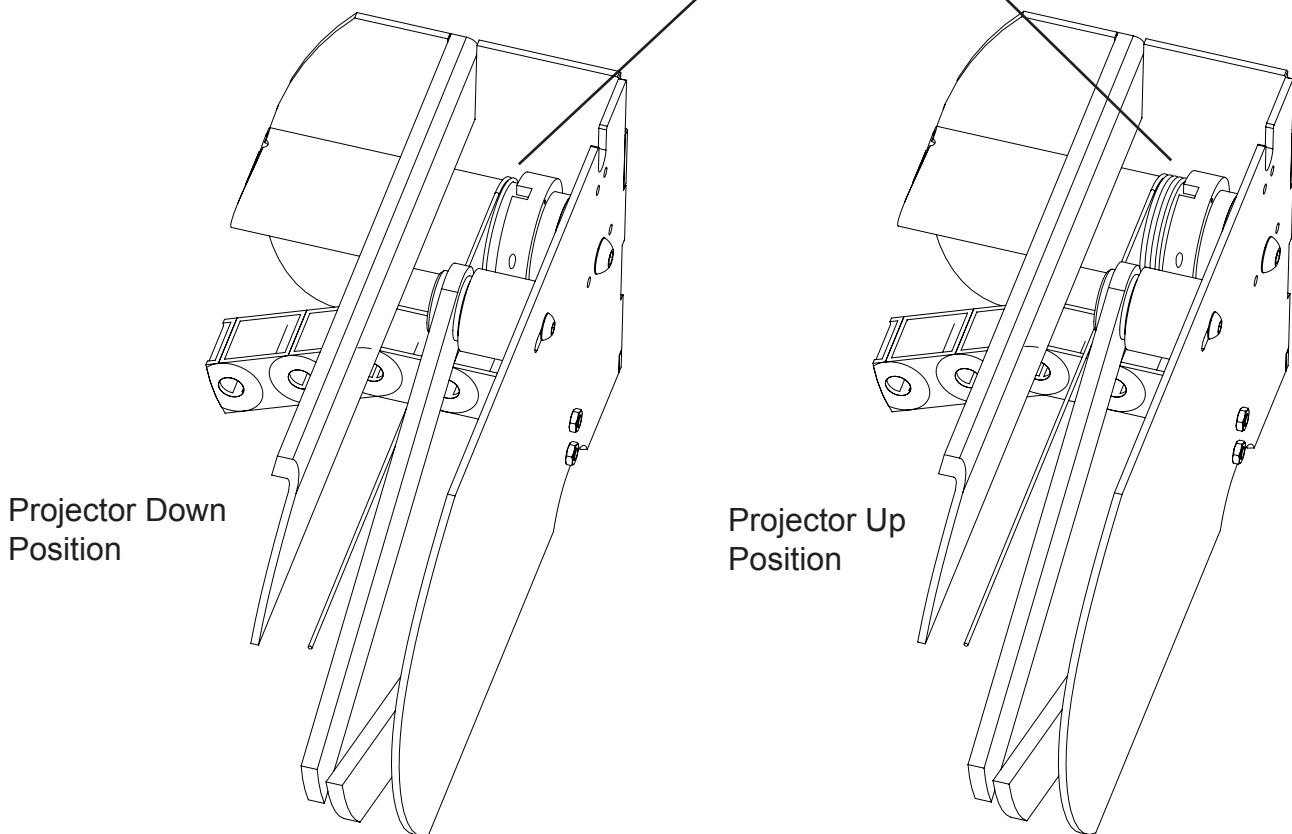

Important

Make sure to check that the cables are set up correctly **No rubbing or overlapping**. They must be as square as possible and neatly coiled close to the collars they connect to.

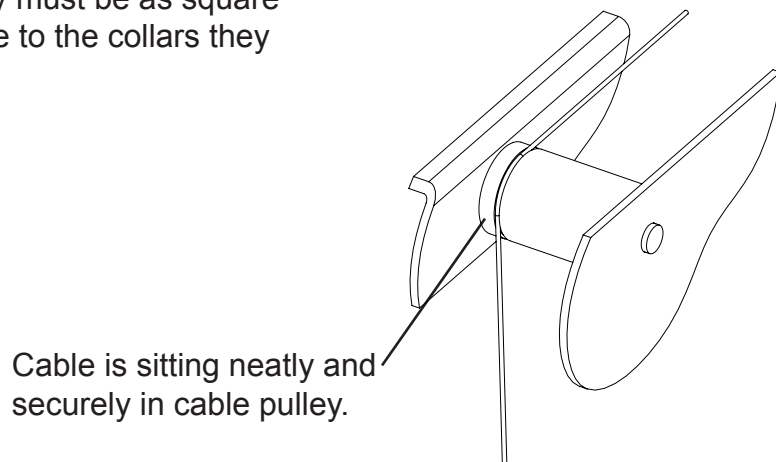

PD1 & 2 - Projector Drop Mechanism



Connections

- The mechanism must be connected to both the AC1 and DC1
- *Optional* - Electric screen can be connected using the control box using the AC2 block
- The AC2 output can only control a 240V / 110V motorised screen to work simultaneously with the projector

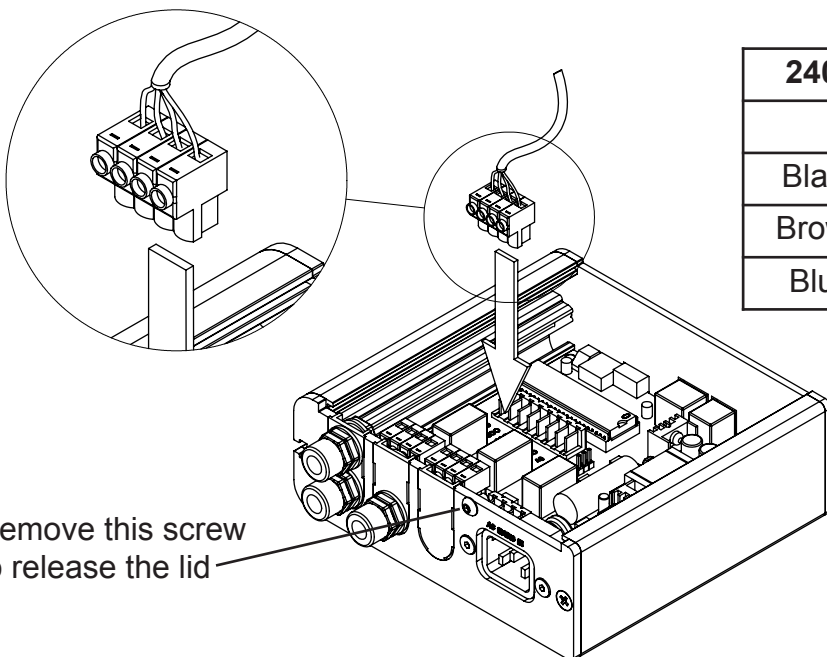
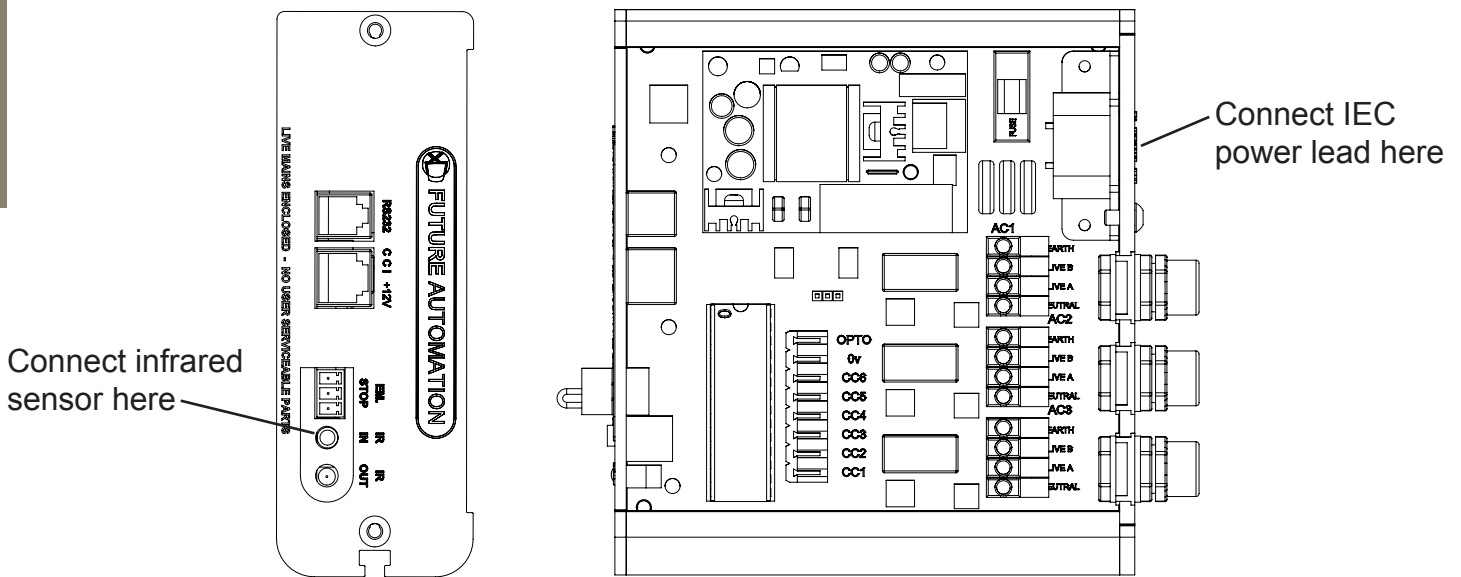

240v	AC1 Connection	110v
	Earth	Green
Black	Live B	Red
Brown	Live A	Black
Blue	Neutral	White

PD1 & 2 - Projector Drop Mechanism



Contact Closure

- Use an RJ45 connector in the CCI socket on the control box to operate via contact closure

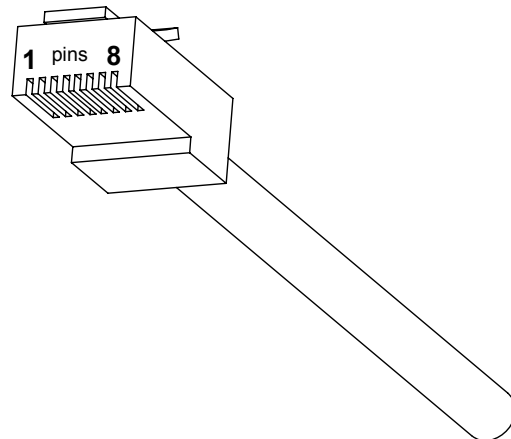

PIN	DESCRIPTION	ACTION	WIRE / CABLE		CONTACT CLOSURE LED INDICATOR
			568A	568B	
1	12V SUPPLY	12V SUPPLY - CURRENT LIMITED	W/G	W/O	
2	12V LATCH	When 12V attached, device will go OUT. When 12V removed, device will go IN.	G	O	
3	GROUND	GROUND	W/O	W/G	
4		PIN 4 NOT USED	BL	BL	
5	DEVICE LATCH	Short to GROUND (pin 3), device will go OUT, remove short device will go IN.	W/BL	W/BL	LED 4
6	DEVICE STOP	Momentary short to GROUND (pin 3), stops device in current position.	O	G	LED 3
7	DEVICE OUT	Momentary short to GROUND (pin 3), makes device go OUT.	W/BR	W/BR	LED 2
8	DEVICE IN	Momentary short to GROUND (pin 3), makes device go IN.	BR	BR	LED 1

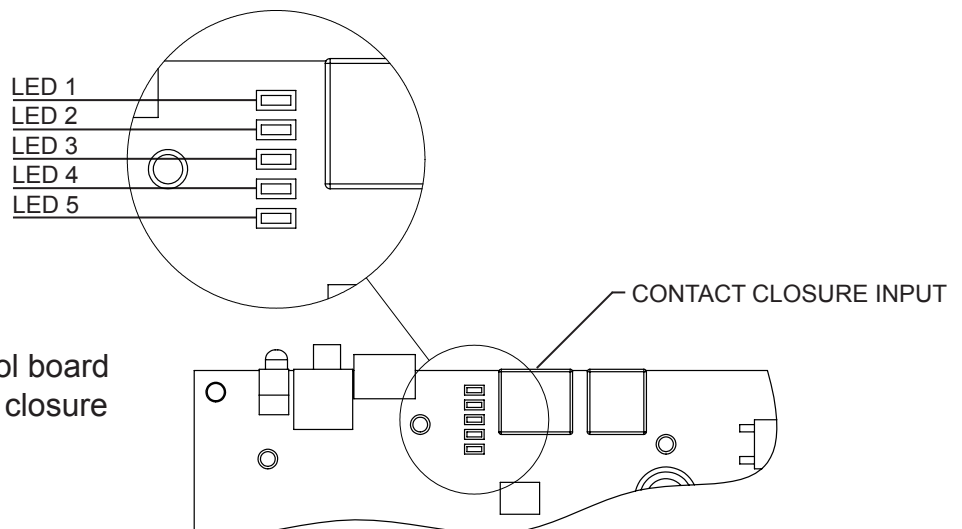

NOTE:
Earlier versions of the control board may not have these contact closure LED indicators.

PD1 & 2 - Projector Drop Mechanism



RS232

- Use an RJ25 connector in the socket marked RS232 on the control box to operate using RS232

Pin 1: RX
Pin 6 : TX
Pin 3 & 4: GROUND

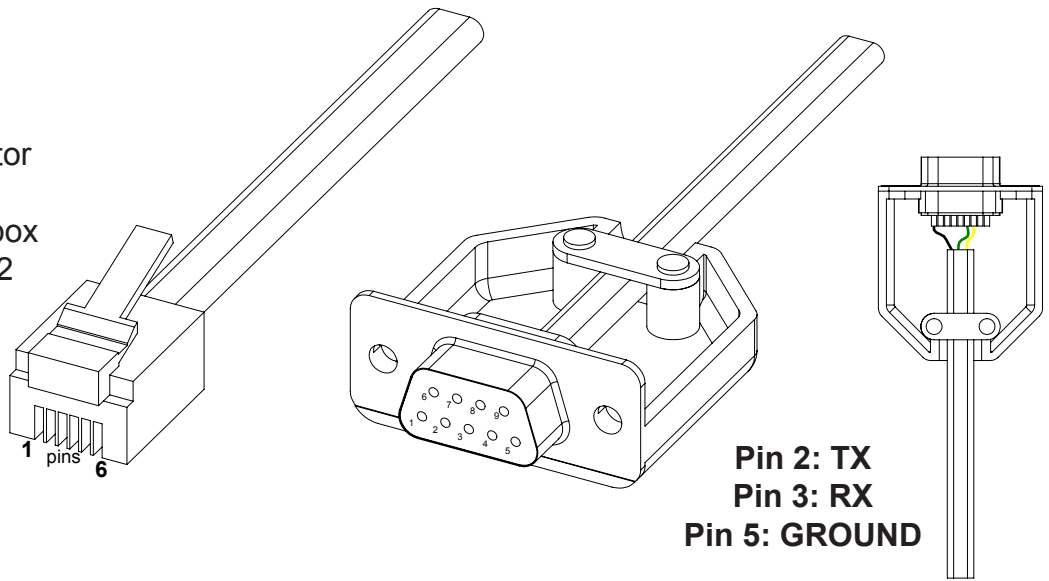

Pin 2: TX
Pin 3: RX
Pin 5: GROUND

Details

Baud rate: 9600
 Stop bit: 1
 Parity: None
 Databits: 8

RJ25		9 PIN D
PIN 1: RX	TO	PIN 2: TX
PIN 6: TX	TO	PIN 3: RX
PIN 3: GROUND	TO	PIN 5: GROUND
PIN 4: GROUND	TO	PIN 5: GROUND



IMPORTANT

Ensure protocol is entered exactly as written, including Carriage Return (Enter / ASCII 13).

Protocol	Action
fa_in Carriage Return (Enter ↵)	Device IN
fa_out Carriage Return (Enter ↵)	Device OUT
fa_stop Carriage Return (Enter ↵)	Device STOP (At any position)

Operation Details

DC1

A low voltage connection for the up stop switch in the mechanism. This must be re-connected if you extend the cables. When the up switch is hit, the connection between CC1 and ground is broken, the LED goes off and the projector drop stops going up.

EMERGENCY STOP

This connection will stop all functions of the mechanism once broken / removed. This is where we recommend wiring a safety device - For a range of safety devices see control, safety & accessories section in product brochure.

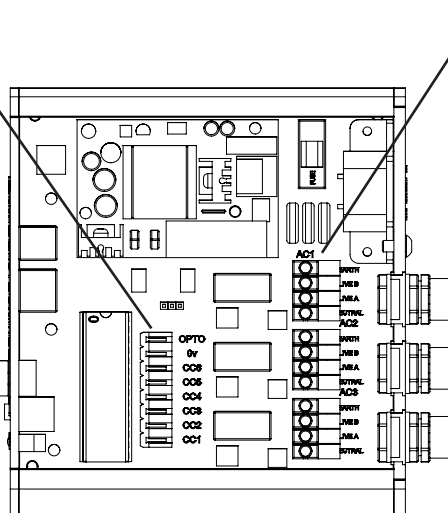

AC1

Gives an output of 240V (or 110V) to control the Projector drop motor.

AC2

Outputs stay live for 120 seconds after the OUT or IN functions are selected.

DC1 - Up Delay

Link CC3 to 0V to delay the projector carriage going in by 3 mins, allowing the projector to cool.

PD1 & 2 - Projector Drop Mechanism



Replacing batteries

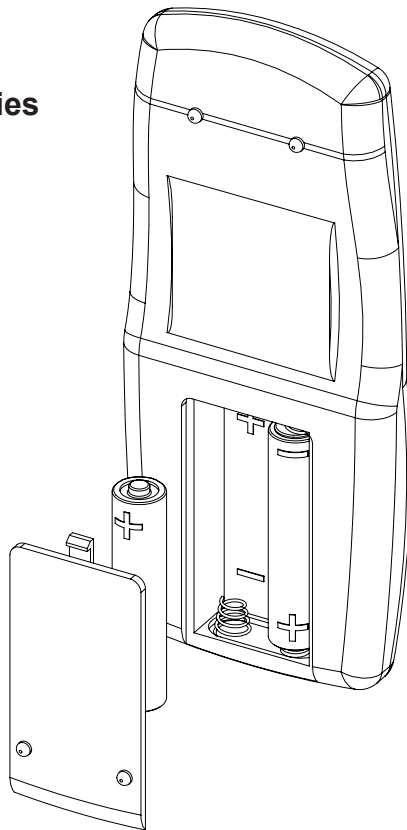

Future Automation IR Remote Controller needs x2 AAA batteries which are provided within the packaging

Operation Buttons

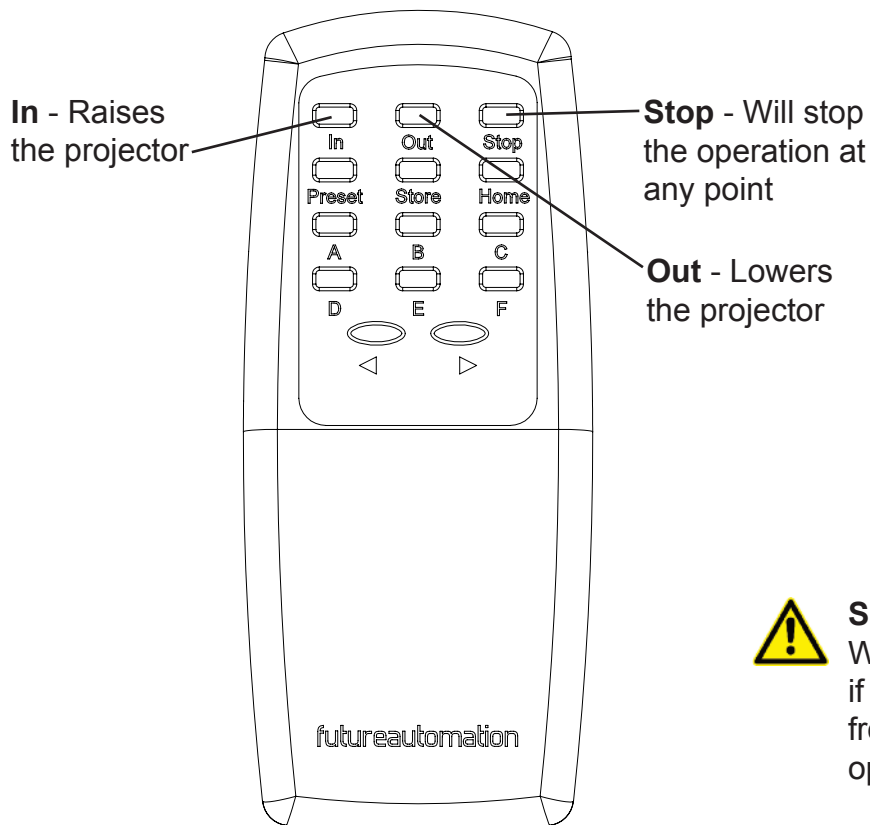

Safety Note

When the mechanism is moving if you press any button apart from IN and OUT it will stop the operation.

PD1 & 2 - Projector Drop Mechanism



PD1 & 2 Projector Drop Mechanism - Trouble shooting guide

Having problems? - Check the following:

1. Are all the connections correct?
2. Is the mechanism being operated correctly?

If the mechanism does not operate correctly, check the items listed in the table below. Should the problem persist, there may be a malfunction. If this is the case, disconnect the mains power immediately and contact your installer

Symptom	Cause	Remedy	Page
Lift not working	Emergency stop removed	Replace emergency stop	14
	Remote control or batteries faulty	Replace batteries or remote	15
	Motor end stops incorrectly set	Adjust end stop	10
Contact closure not working	Incorrect pin configuration	Terminate 8-pin RJ45 to 568/b pin configuration	13
	Faulty wiring	Replace connector or cable	13
	Faulty control box	Test contact closure on control box	13
RS232 not working	Incorrect settings	Refer to instructions	14
	Incorrect pin configuration	Terminate 6-pin RJ11 to configuration supplied	14
	ASC11 protocol error	Amend Protocol	14
Lift not level	Cables over lapping/damaged	re-seat cables	11

PD1 & 2 - Projector Drop Mechanism



Test motor operation

If the lift is not working, you can test the motor directly. To do so, you will need to locate and open the control box.

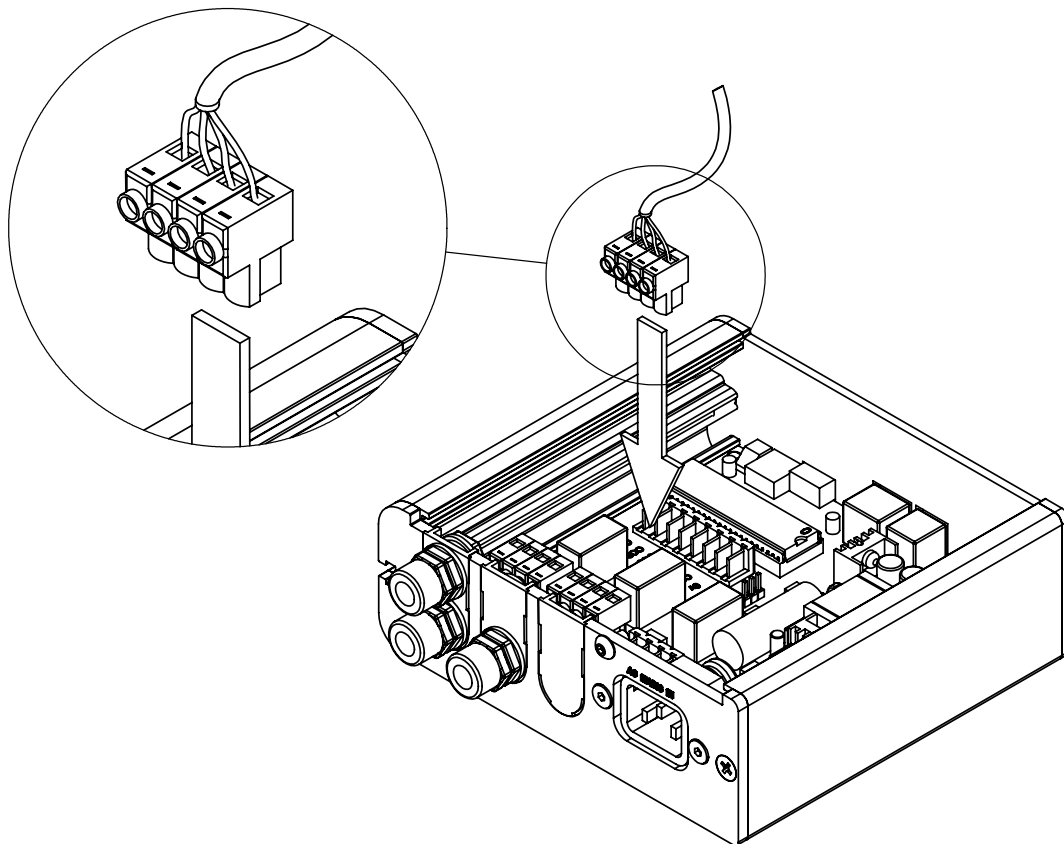

CAUTION. Apply mains voltage taking all necessary grounding precautions.

Use live (brown) and switch live (black) to change direction of motor. If the motor works, contact manufacture to replace control box.

PD1 & 2 - Projector Drop Mechanism



Notes...



Future Automation

Unit 2 Kimpton Enterprise Park
Claggy Road
Kimpton
Hertfordshire
SG4 8HP
United Kingdom

Tel: +44 (0) 1438 833 577

Fax: +44 (0) 1438 833 565

Email: info@futureautomation.co.uk

www.futureautomation.co.uk