

Installation Instructions

PIC SP - Picture Split Mechanism

Design Highlights

- Range of Sizes of Mechanism
- Smooth Quiet Motion
- Optional to Combine with a Motorised Bracket
- Complete Sheet Metal Cassette Ensures Simple Installation
- Range of Panel Designs Available

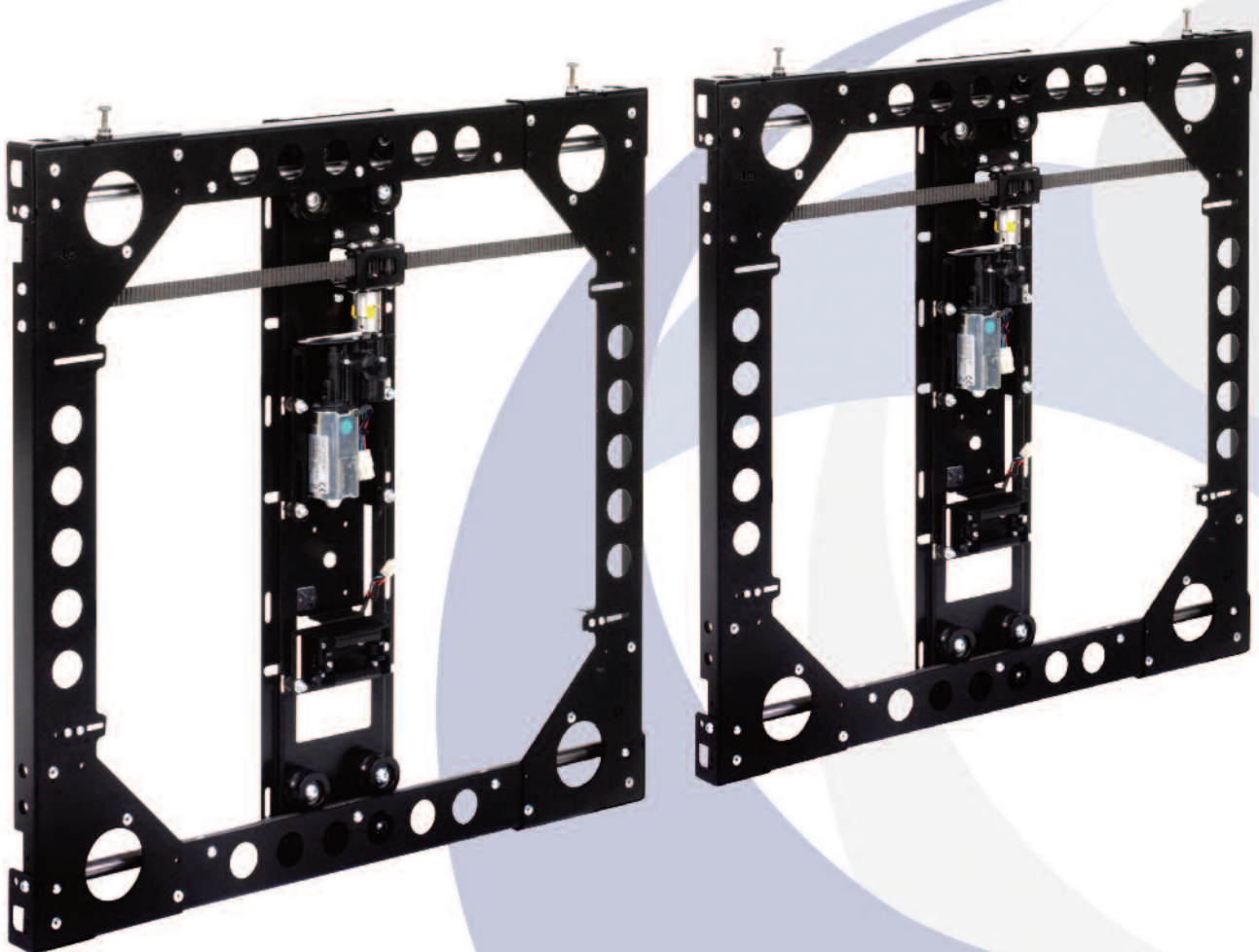

Thank you for choosing
futureautomation

PIC SP - Picture Split Mechanism



Caution
Warning



Beware of
Moving Parts



Danger
Electricity



Keep Hands
Clear

Safety Disclaimer

Important Safety Instructions

Explanation of graphical symbols

-(Electric Shock Symbol) = The lightning flash within an equilateral triangle is intended to alert you to the presence of un-insulated "dangerous voltage" within the products enclosure that may be of sufficient magnitude to constitute an electric shock to persons

-(Caution Symbol) = The exclamation point within an equilateral triangle is intended to alert you to the presence of important operating and maintenance (servicing) instructions in the literature accompanying the product

-(Tools Symbols) = The tools symbol within a coloured square are intended to highlight the required tools necessary for correct and safe installation of the product. These are intended as a guide only, and it is at the installer's discretion as to which tools are used.

WARNING: RISK OF ELECTRIC SHOCK, ONLY AUTHORIZED INSTALLERS TO OPEN THE POWER CONTROL BOX.

WARNING: To reduce the risk of fire or electric shock, do not expose electrical parts to rain or moisture, unless the product has been specifically designed to do so.

WARNING: Failure to provide adequate structural strengthening, prior to installation can result in serious personal injury or damage to the equipment. It is the installer's responsibility to ensure the structure to which the component is affixed can support the four times the weight of the component.

WARNING: Do not exceed the weight capacity. This can result in serious personal injury or damage to the equipment. It is the installer's responsibility to ensure that the total combined weight of all attached components does not exceed that of the maximum figure stated.

WARNING: Failure to provide adequate structural strength for this component can result in serious personal injury or damage to equipment! It is the installer's responsibility to make sure the structure to which this component is attached can support five times the combined weight of all equipment. Reinforce the structure as required before installing the component.

Warnings:

1. **Read all technical instructions fully before installation and use. It is the installer's responsibility to ensure that all documentation is passed on the end user and read fully before operation.**
2. **Keep all documentation.**
3. **Heed all warnings.**
4. **Follow all technical specifications and instructions during installation.**
5. **Do not use near water unless the product has been specifically designed to do so.**
6. **Clean only with a dry cloth.**
7. **Do not defeat the purpose of the polarized or grounding type plug. A polarized plug has two blades, one wider than the other. A grounding type plug has two blades and a grounding prong. The wide blade or third prong are provided for your safety. If the provided plug does not fit your outlet, consult an electrician or contact the manufacturer.**
8. **Protect the power cord from being walked on or pinched, particularly at plugs, convenience receptacles, and the point where the exit from the apparatus.**
9. **Unplug the apparatus during lightning storms or when unused for long periods of time.**
10. **Only use attachments/accessories specified by the manufacturer.**
11. **Refer all servicing to qualified personnel. Servicing is required regularly on an annual basis, when the apparatus is damaged in any way, liquid has been spilled or objects have fallen into the apparatus, the apparatus has been exposed to rain or moisture, does not operate normally, or has been dropped.**
12. **To completely disconnect the apparatus from the AC mains, disconnect the power cord plug from the AC receptacle on the power control box.**
13. **To prevent overheating, do not cover the apparatus. Install in accordance with the instructions.**
14. **UK, Ireland and Hong Kong only – The power cord is supplied with a 13A plug having an earthing pin. The apparatus is earthed and this pin is not required for safety, merely to operate the safety shutter of mains outlet.**
15. **No naked flames such as lit candles should be placed on the unit.**
16. **Observe and follow the local regulations when disposing of batteries.**
17. **Do not expose the unit to dripping or splashing fluids.**
18. **Do not place objects filled with liquid, such as vases, on the unit.**
19. **Do not expose the batteries to excessive heat such as sunshine, fire or the like.**
20. **For all mounted apparatus, the apparatus should be installed on solid wood, bricks, concrete or solid wood columns and battens.**
21. **Always turn off power at source before putting on or taking off parts and cleaning.**
22. **Do not use outdoors unless marked for outdoor use.**
23. **Exceeding the weight capacity can result in serious personal injury or damage to equipment.**

Future Sound & Vision trading as Future Automation intend to make this and all documentation as accurate as possible. However, Future Automation makes no claim that the information contained herein covers all details, conditions or variations, nor does it provide for every possible contingency in connection with the installation or use of this product. The information contained in this document is subject to change without prior notice or obligation of any kind. Future Automation makes no representation of warranty, expressed or implied, regarding the information contained herein. Future Automation assumes no responsibility for accuracy, completeness or sufficiency of the information contained in this document.

PIC SP - Picture Split Mechanism

Contents	Page
Introduction	
Safety Information	1
Contents	2
Contents	3
Tool Indicator Icons	3
Installation	
Parts List	4
Package Contents	4
Stage 1	
Before You Start Check	5
Marking Mechanisms Positions	5
Stage 2	
Mounting The Mechanism	6
Stage 3	
Mounting The Mechanism	7
Control Box Set Up	7
Stage 4	
Testing The Mechanism	8
Stage 5	
Fitting The Moving Panel To The Mechanism	9
Stage 6	
Adjusting The Stop Positions	10
Stage 7	
Mounting The Screen	11
Stage 8	
Controlling The Mechanism	12
Final Checks	12
Mechanism Movement	12
Electrical Connections	
Electrical Connections In The Control Box	13
Contact Closure	14
Warning Lights	15
RS232	15
Wiring & Control Box Details	15
Operations	16
Remote Control	16
Operation Buttons	16
Changing The Batteries	16
Trouble Shooting	17/18
Technical Overview	19

PIC SP - Picture Split Mechanism

Tool Indicator Icons

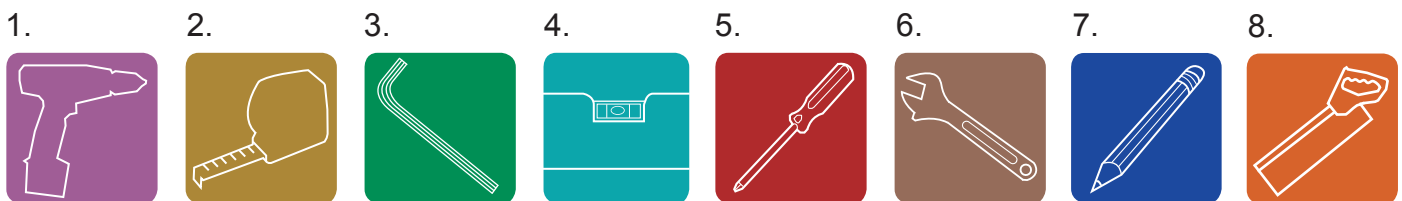

1. - Drill
2. - Tape measure

3. - Allen Keys
4. - Spirit Level

5. - Screwdrivers
6. - Spanners

7. - Pencil
8. - Saw

Product Warranty

This product carries a warranty that covers the cost of labour and spare parts incurred by any defects in materials and workmanship under normal use during a two year period from date of purchase. Support for any problems that are not hardware faults are excluded from the warranty entitlement. This warranty does not affect your statutory consumer rights.

The following is excluded from warranty service:

- Malfunctioning caused by misuse or damage, accidental or otherwise, or service modification by persons not authorised by Future Automation, or the use of any non Future Automation supplied parts;
- Any electrical, or other environmental work external to your Future Automation mechanism including power cuts, surges or lightning strikes;
- Additional items not supplied by Future Automation although they may have been supplied together by the retailer;
- Any 3rd party software products controlling your mechanism;
- Any transfer of ownership. Warranty is provided only to the initial purchaser;
- Compensation for loss of use of the product, and consequential loss of any kind;
- Use of the product over the specified weight capacity;
- Any damage to products during transit that is not checked and notified as “unchecked” or “damaged” upon receipt of delivery.

Any part of your system that needs to be replaced during a warranty repair becomes the property of Future Automation.

PIC SP - Picture Split Mechanism

Package Contents

- 1 - Mechanism
 - 1.1 - Frame Horizontal Member
 - 1.2 - Frame Vertical Member
 - 1.3 - Drive Belt
 - 1.4 - Motor
 - 1.5 - Wall Plate
 - 1.6 - x8 Moving Panel Brackets
 - 2 - Control Box
 - 3 - IR Remote Control
- Not Shown On Page**
- 4 - x2 AAA Batteries
 - 5 - x8 M6 Nuts & Bolts
 - 6 - Mains Power & Other Leads



Mechanisms supplied as a pair

PIC SP - Picture Split Mechanism.

Available in 3 standard sizes, PIC SP1, 2 & 3.

Custom sizes also available.

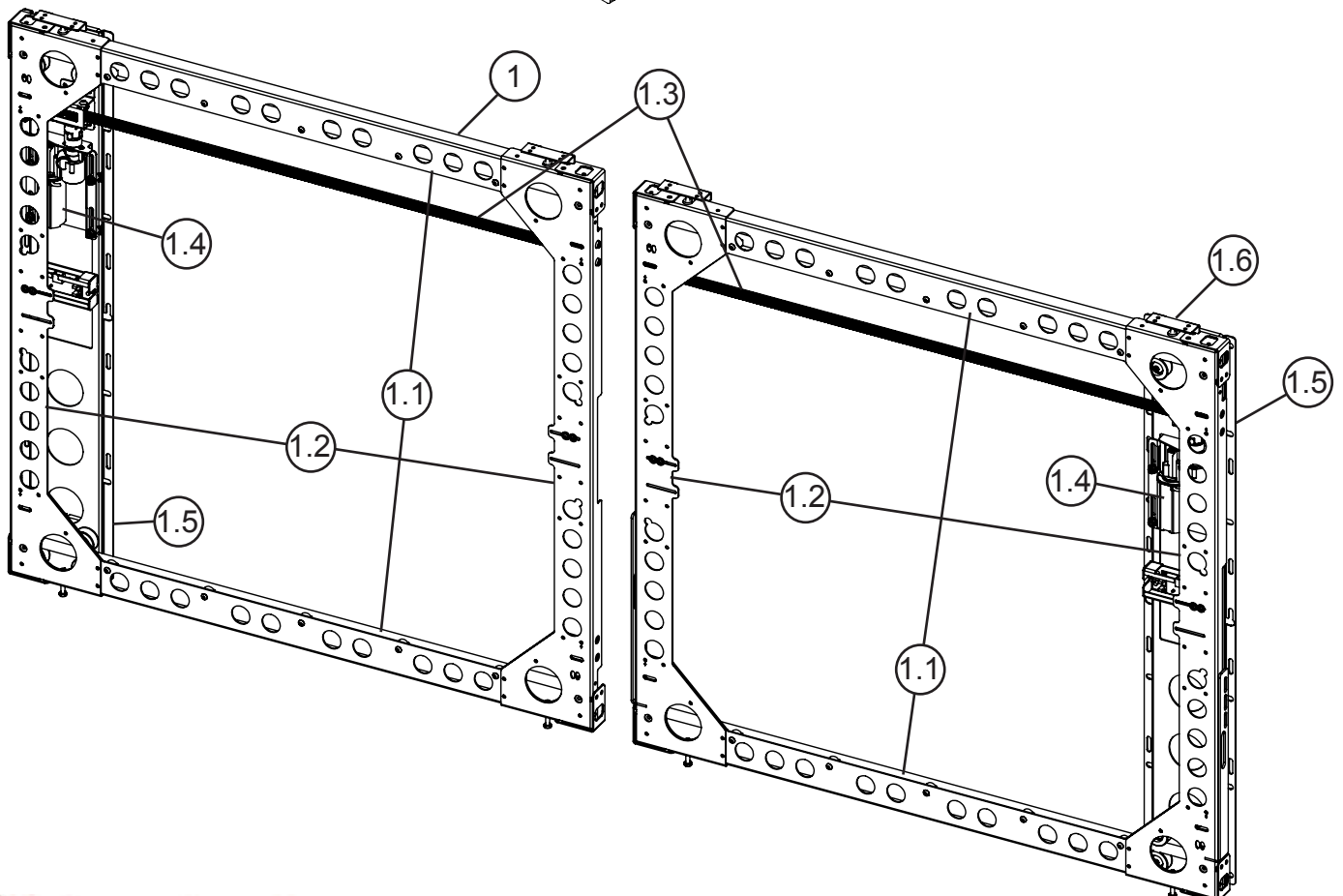
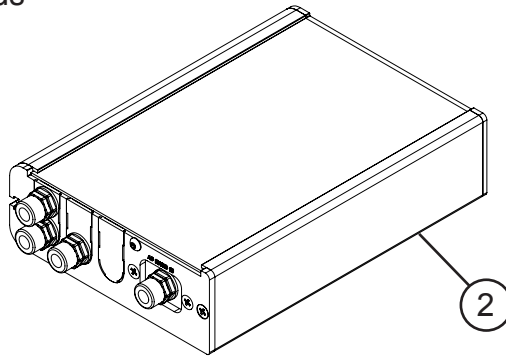
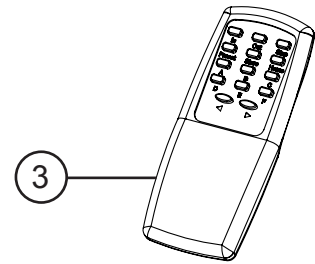

PIC SP - Picture Split Mechanism

Before you Start Check, Check the Following:

- The product is in good condition
- No damage to any parts

Marking Mechanisms Positions

You will receive your mechanisms with the wall plate in the centre of the frame. This is in the easiest position to mount straight onto the wall.

Start by marking where the mechanism will go on the wall. Mark centre points through both the key hole slots, shown in the right detail view. Make sure the mechanism is level using a spirit level.

These dimensions can differ depending on the moving panel frame work.

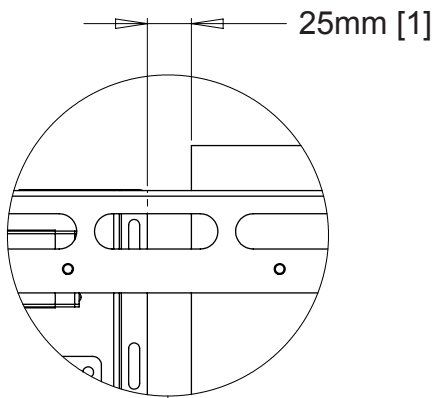

Refer to the Tech Sheets for further dimensions

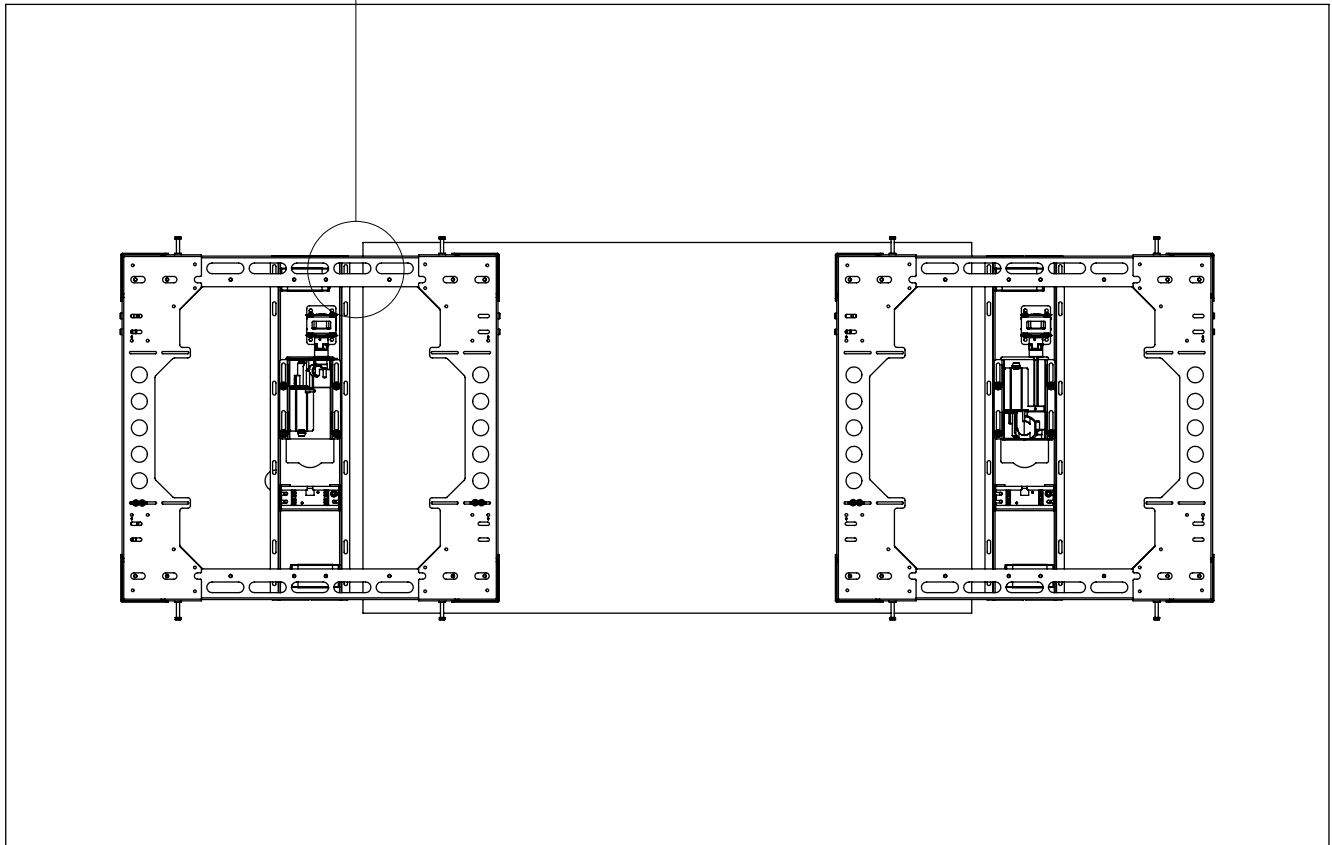

PIC SP - Picture Split Mechanism



Mounting the Mechanism

Once marked, put appropriate fixings into the marked points. Offer the mechanism to the wall and secure in place using appropriate fixing.

Make sure to run the mechanism power cables through the hole in the wall

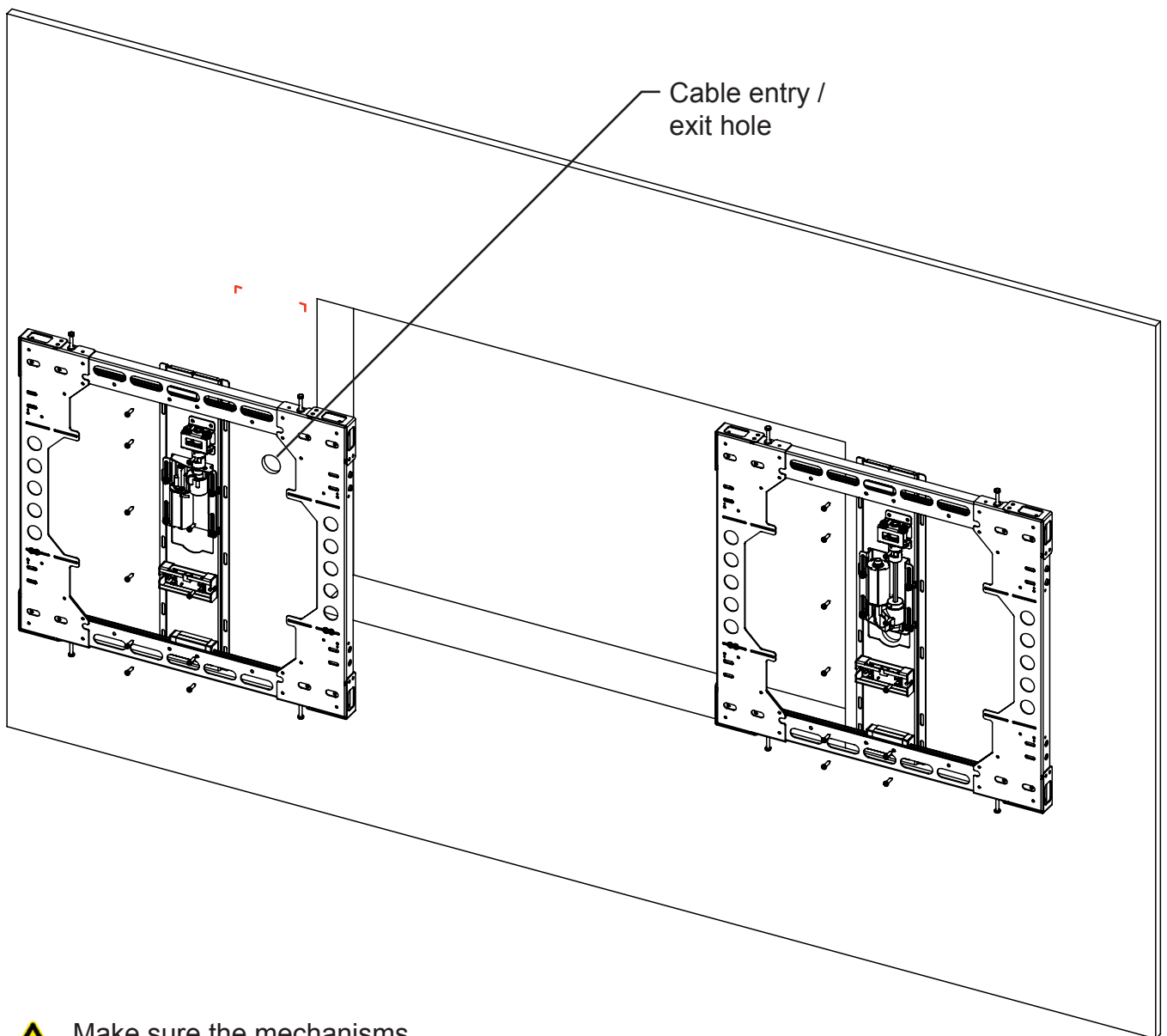

 Make sure the mechanisms are level using a spirit level.

PIC SP - Picture Split Mechanism



Final Mounting Fixings

Be sure to use as many fixings through the various slots as possible.



Make sure the mechanisms are fixed securely and safely.

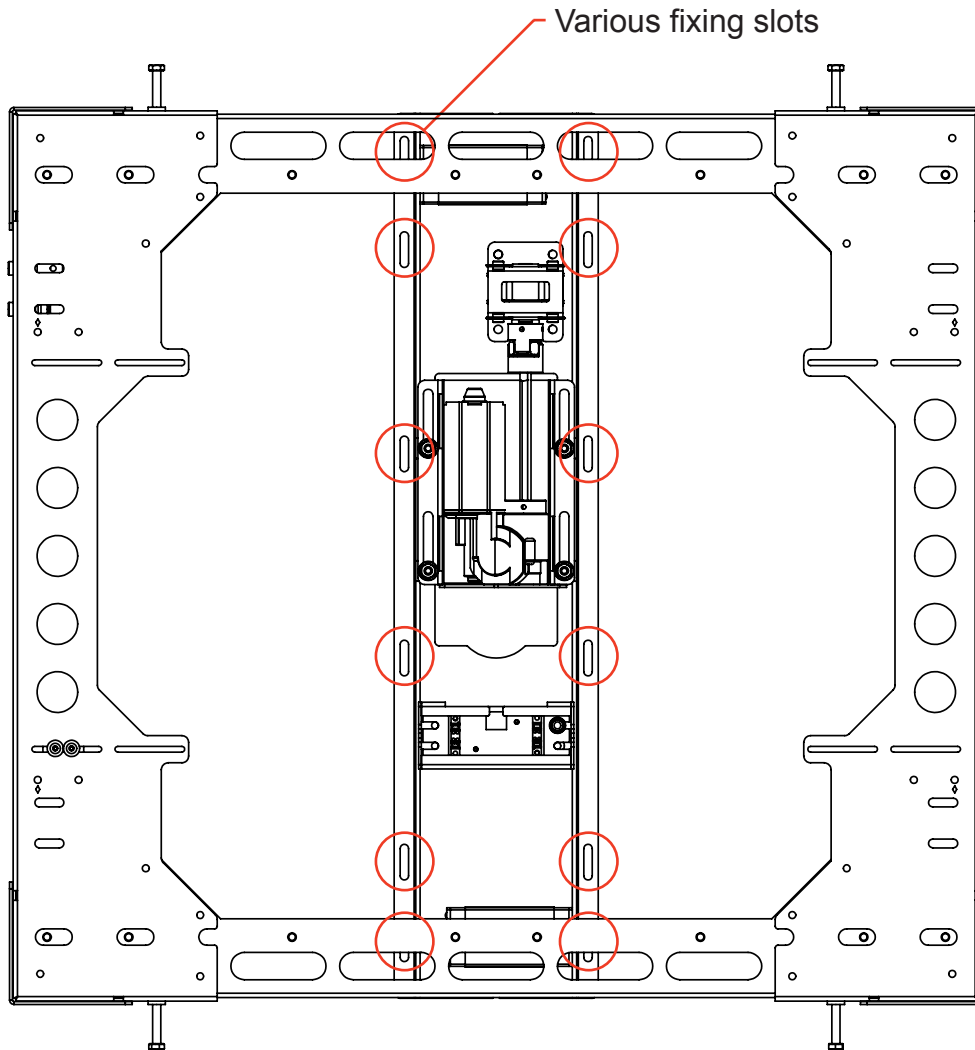

Control Box Setup



- THE CONTROL BOX MUST BE IN AN EASILY ACCESSIBLE LOCATION
- Wire up the control box, refer to page 13 Electrical Connection
- Connect the control box to the mains power supply
- Connect the infrared remote sensor even if you are going to use switch control
- Cables can be easily extended

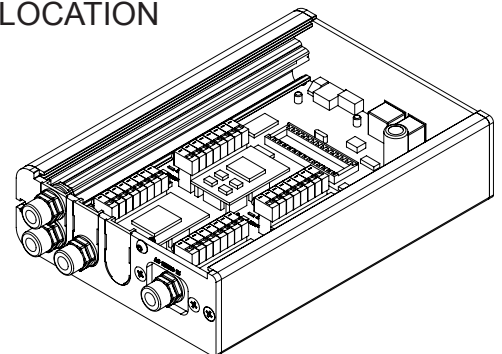

PIC SP - Picture Split Mechanism



Testing the Mechanism

This is a good time to run and test the mechanism. Make sure the frame is square and won't clash the moving panels into one another once mounted. Make sure the control box is connected correctly and the cables won't catch on the mechanism.

Controlling the Mechanism

The supplied IR remote performs the following functions:

OUT: Reveal Screen

IN: Hide Screen

STOP: Stop

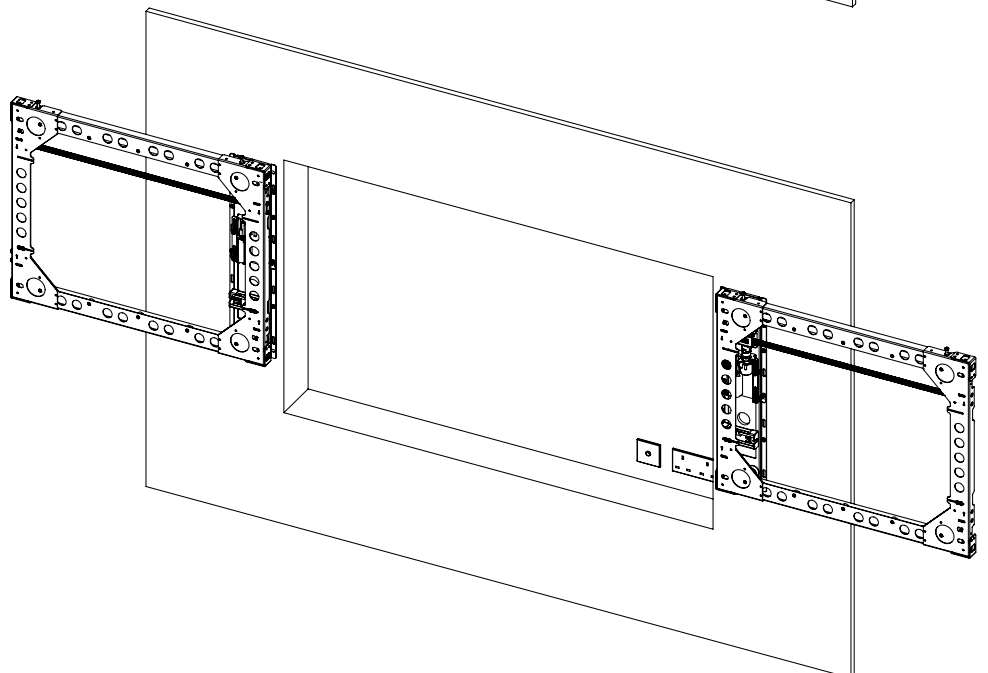
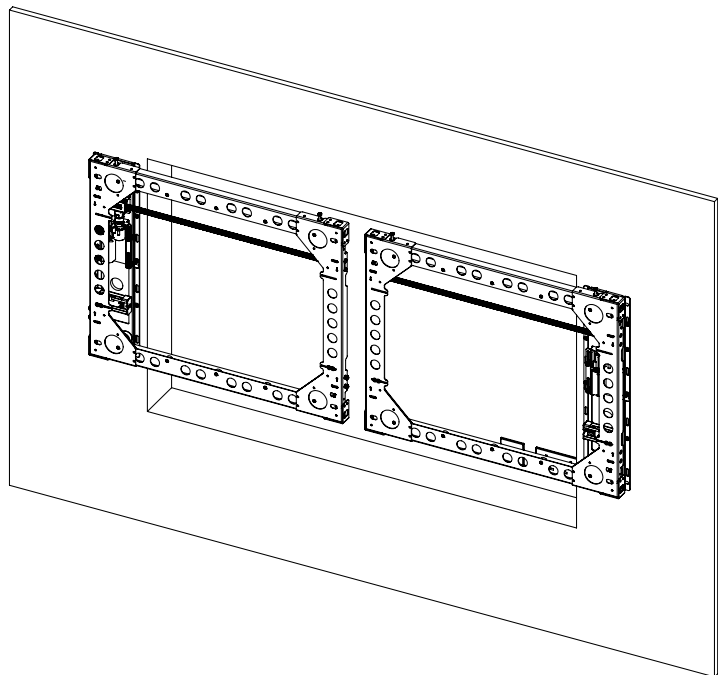
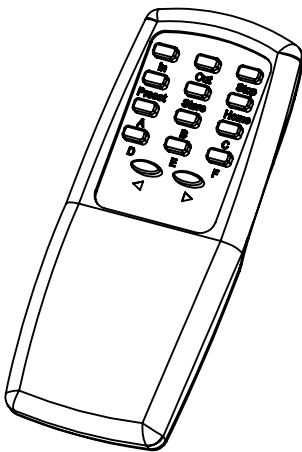

Safety Note

When the mechanism is moving if any button is pressed apart from IN and OUT it will stop the operation.

PIC SP - Picture Split Mechanism



Fitting the Moving Panels to the Mechanisms

To make sure the moving panel doesn't fall off the mechanism attach the moving panel brackets as shown.

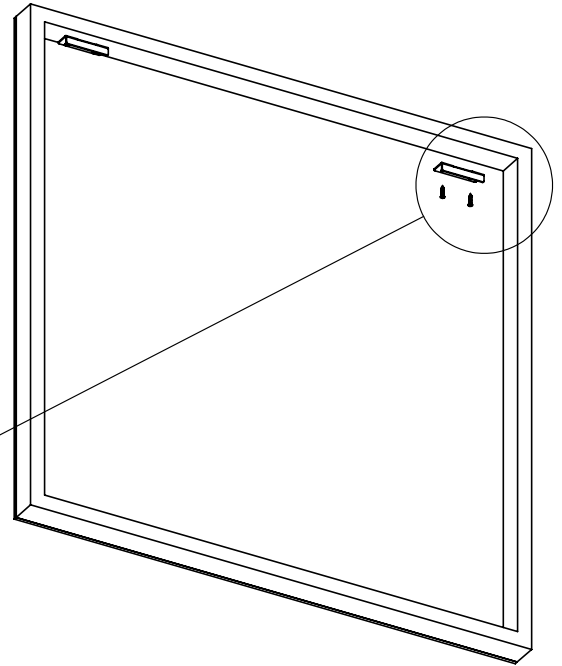
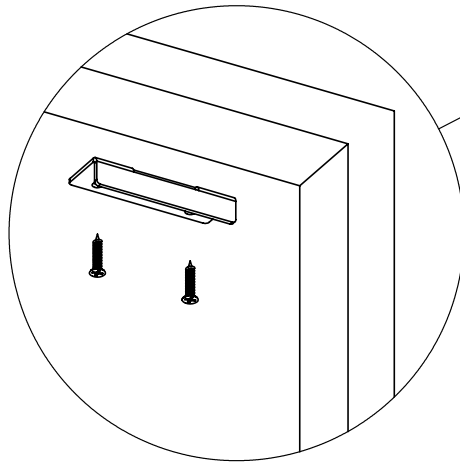

To alter the level of the moving panel adjust the height of these bolts which the moving panel brackets sit on.

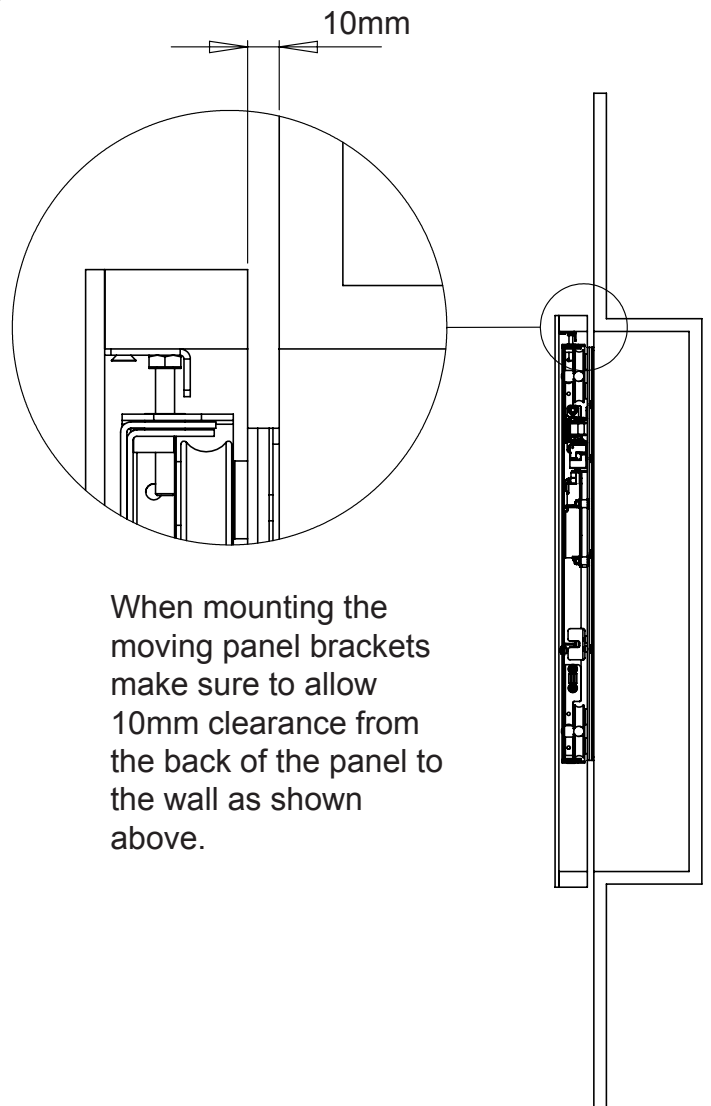
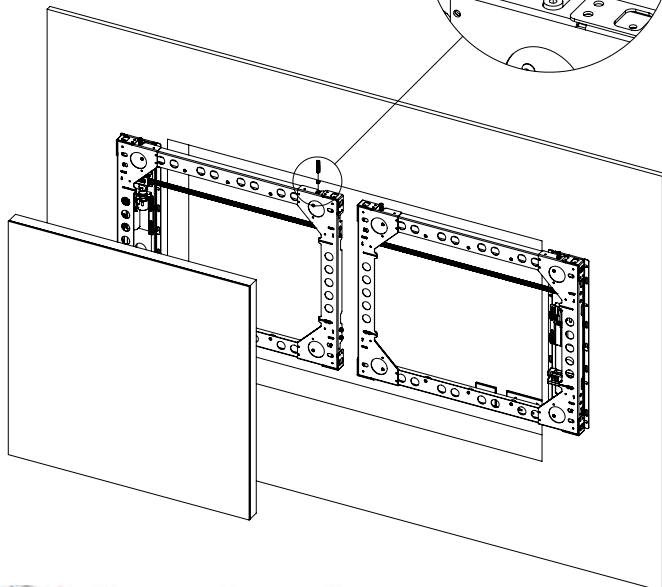
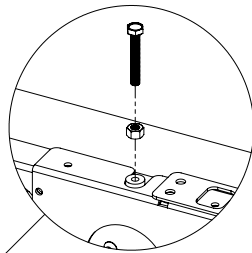

When mounting the moving panel brackets make sure to allow 10mm clearance from the back of the panel to the wall as shown above.

PIC SP - Picture Split Mechanism



Adjusting the Stop Positions

To alter the stopping positions of the moving panels loosen these 2 bolts on both sides and then slide the bracket left to right to determine the finish positions.

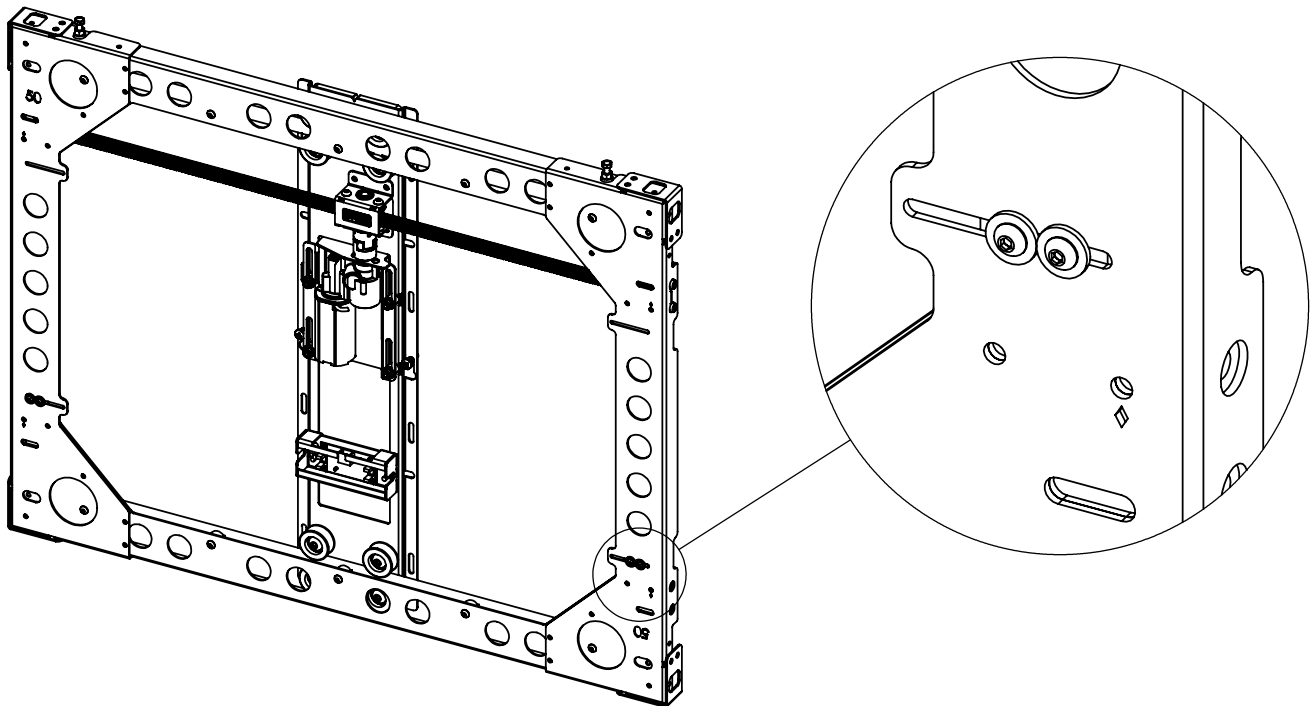

PIC SP - Picture Split Mechanism



Optional, Mounting the Screen

In some cases the moving panels will be hiding something else other than a screen such as a safe or hi-fi which might already be installed otherwise mount the screen into the recess. A range of screen mounts can be found in our catalogue or website. Models we recommend are the V2, V3, V63, V74 & PF60. The V74 mount is shown within the diagram mounting a 55" screen.

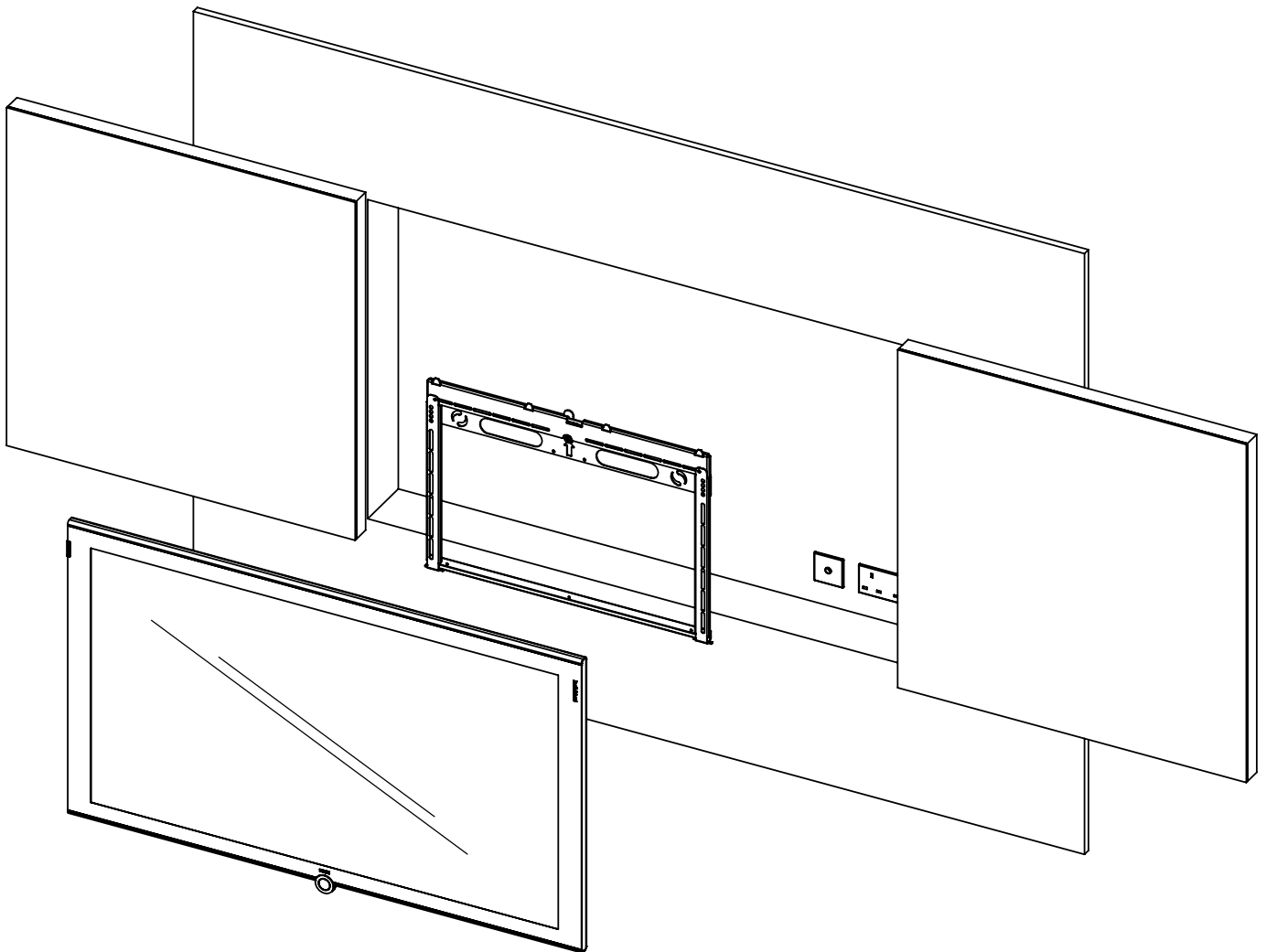

PIC SP - Picture Split Mechanism



Final Checks

Make sure the mechanism is fixed securely and safely and nothing is in the path of the moving panel.

Mechanism Movement

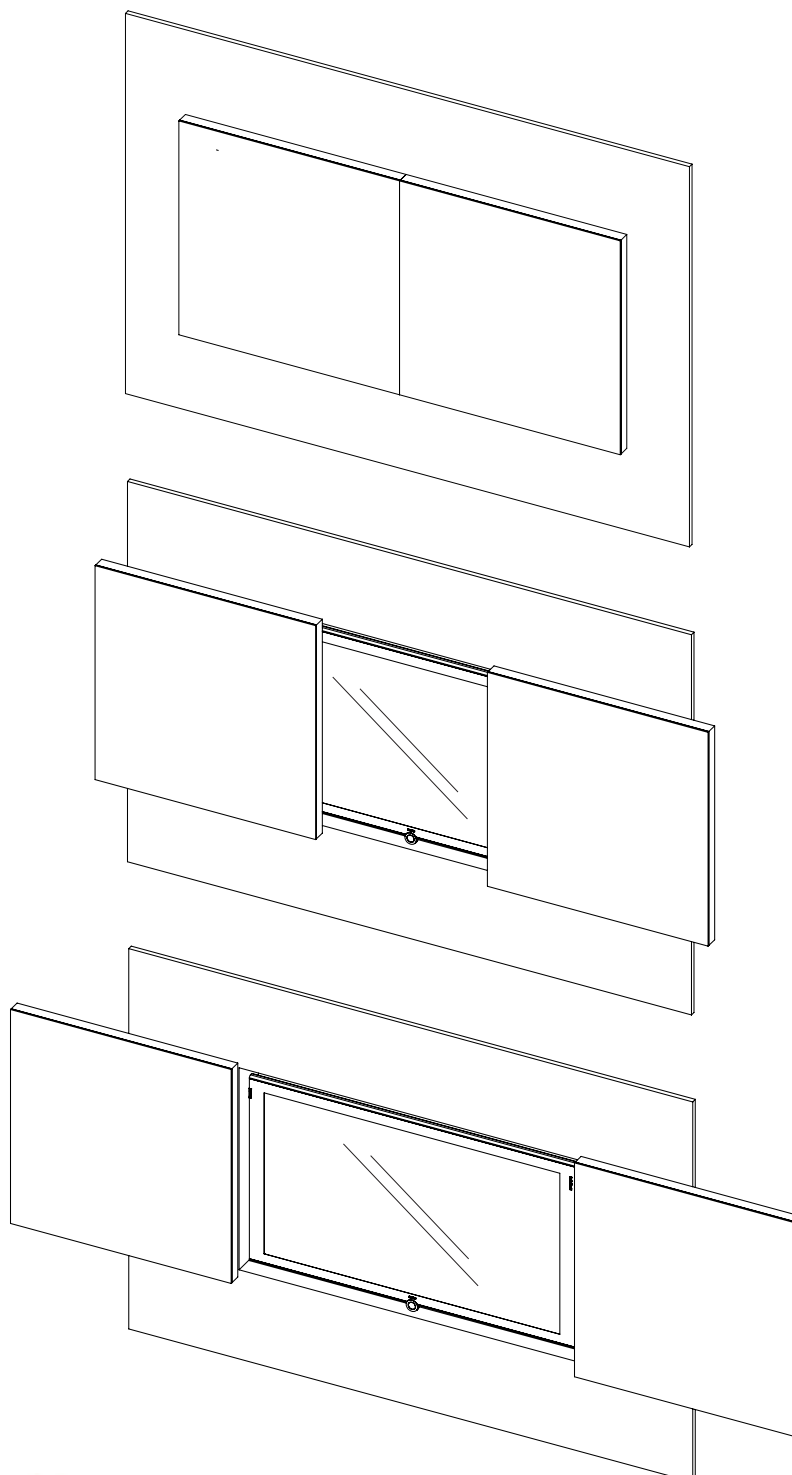



PIC SP - Picture Split Mechanism

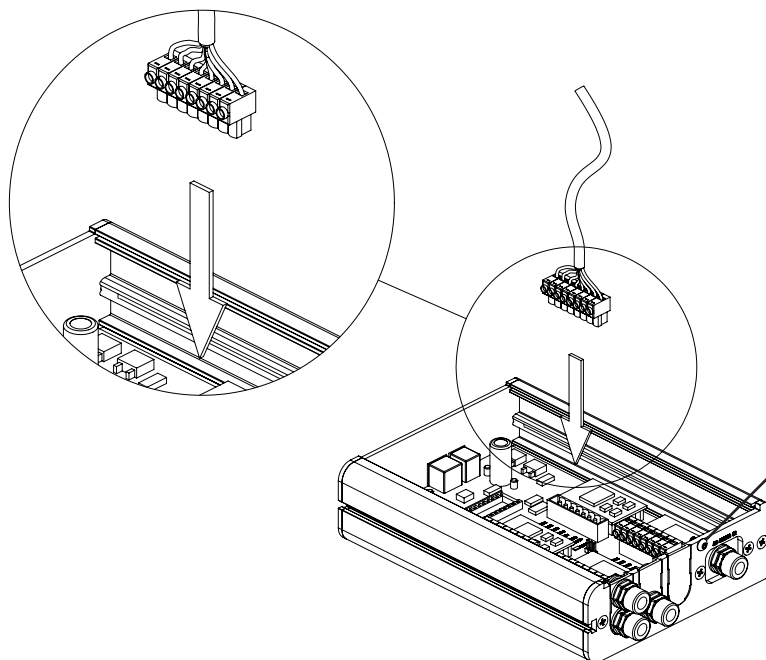
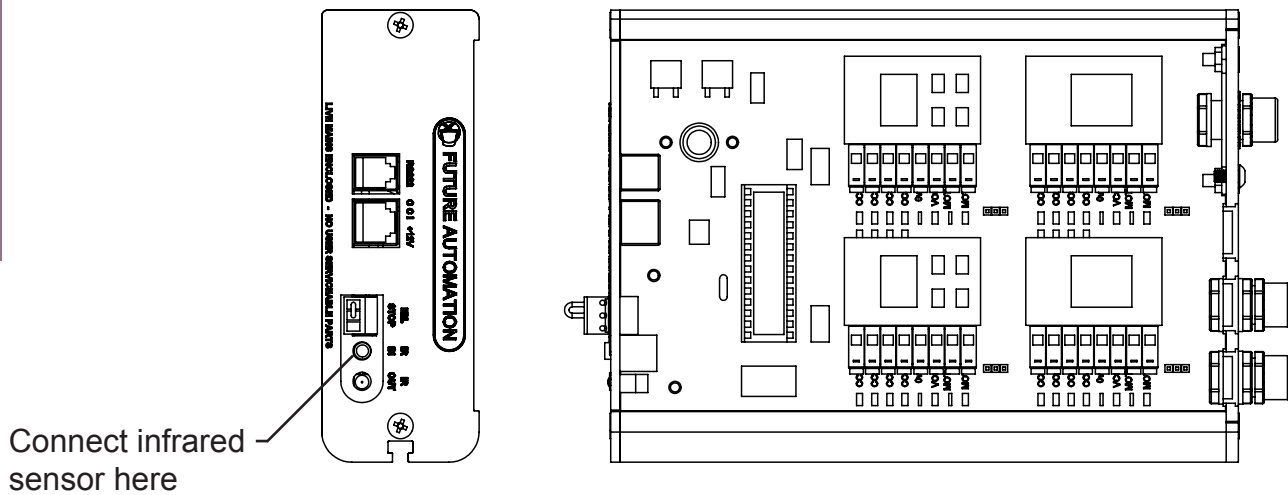

Connections

- The mechanism must be connected to all DC controls



 Ensure the plug is connected correctly and secure

Remove this screw to release the lid

PIC SP - Picture Split Mechanism



Contact Closure

- Use an RJ45 connector in the CCI socket on the control box to operate via contact closure

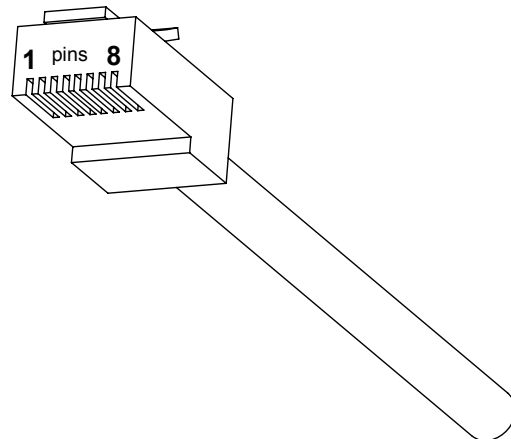

PIN	DESCRIPTION	ACTION	WIRE / CABLE		CONTACT CLOSURE LED INDICATOR
			568A	568B	
1	12V SUPPLY	12V SUPPLY - CURRENT LIMITED	W/G	W/O	
2	12V LATCH	When 12V attached, device will go OUT. When 12V removed, device will go IN.	G	O	
3	GROUND	GROUND	W/O	W/G	
4		PIN 4 NOT USED	BL	BL	
5	DEVICE LATCH	Short to GROUND (pin 3), device will go OUT, remove short device will go IN.	W/BL	W/BL	LED 4
6	DEVICE STOP	Momentary short to GROUND (pin 3), stops device in current position.	O	G	LED 3
7	DEVICE OUT	Momentary short to GROUND (pin 3), makes device go OUT.	W/BR	W/BR	LED 2
8	DEVICE IN	Momentary short to GROUND (pin 3), makes device go IN.	BR	BR	LED 1

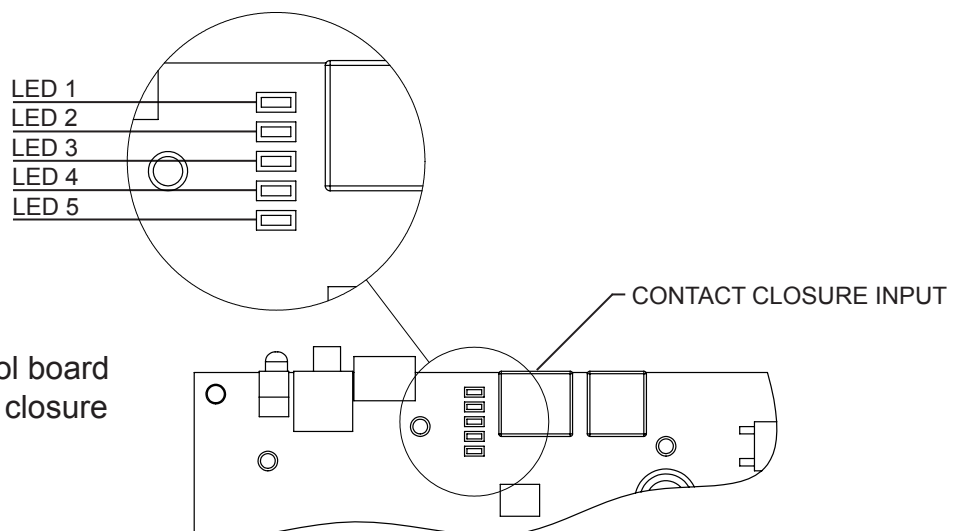

NOTE:
Earlier versions of the control board may not have these contact closure LED indicators.

PIC SP - Picture Split Mechanism



RS232

- Use an RJ25 connector in the socket marked RS232 on the control box to operate using RS232

Pin 1: RX
Pin 6 : TX
Pin 3 & 4: GROUND

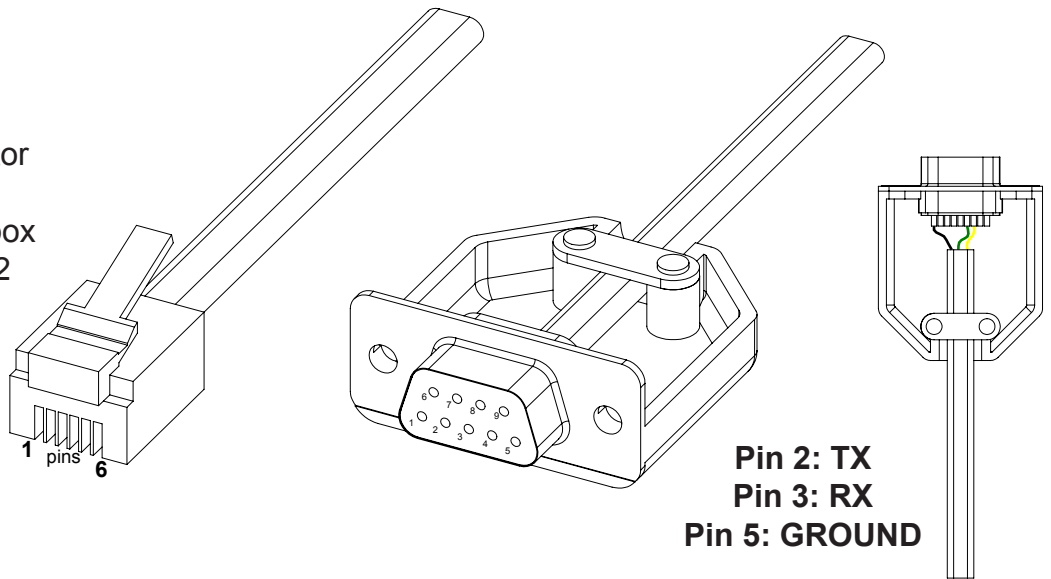

Pin 2: TX
Pin 3: RX
Pin 5: GROUND

Details

Baud rate: 9600
 Stop bit: 1
 Parity: None
 Databits: 8

RJ25		9 PIN D
PIN 1: RX	TO	PIN 2: TX
PIN 6: TX	TO	PIN 3: RX
PIN 3: GROUND	TO	PIN 5: GROUND
PIN 4: GROUND	TO	PIN 5: GROUND



IMPORTANT

Ensure protocol is entered exactly as written, including Carriage Return (Enter / ASCII 13).

Protocol	Action
fa_in Carriage Return (Enter ↵)	Device IN
fa_out Carriage Return (Enter ↵)	Device OUT
fa_stop Carriage Return (Enter ↵)	Device STOP (At any position)

Operation Details

DC3

Controls low voltage (5V) optical sensing end stop positions for left panel

DC1

Controls DC motor for left panel

DC2

Controls DC motor for right panel

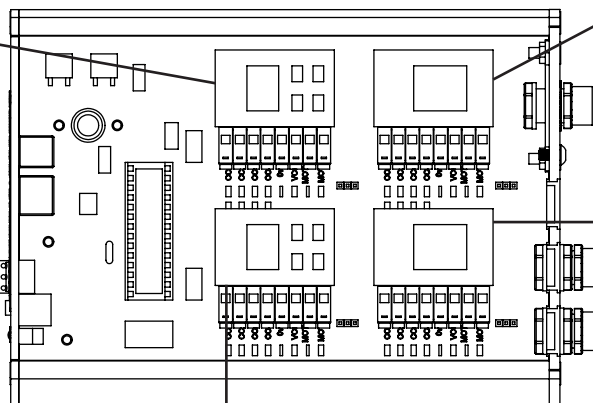

DC4

Controls low voltage (5V) optical sensing end stop positions for right panel



EMERGENCY STOP

This connection will stop all functions of the mechanism once broken / removed. This is where we recommend wiring a safety device - For a range of safety devices see control, safety & accessories section in product brochure

PIC SP - Picture Split Mechanism



Replacing Batteries

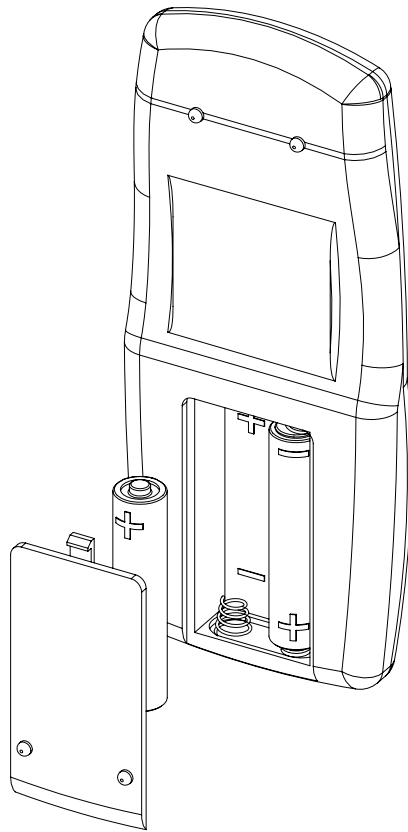

Future Automation IR Remote Controller needs x2 AAA batteries which are provided within the packaging

Operation Buttons

In - Hides the screen

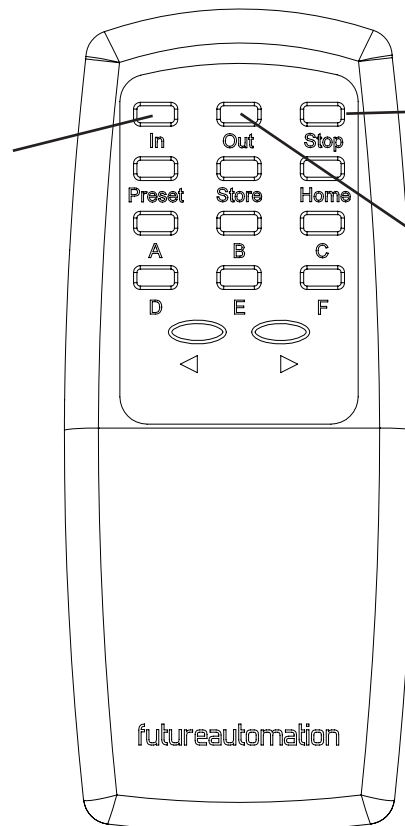

Stop - Will stop the operation at any point

Out - Reveals the screen

Mechanism Reference

Store + Store + Right ▷
Clears Memory

Store + Store + Out
References Mechanism



Safety Note

When the mechanism is moving if you press any button apart from IN and OUT it will stop the operation.

PIC SP - Picture Split Mechanism



PIC SP Picture Split Mechanism - Trouble Shooting Guide

Having problems? - Check the following:

1. Are all the connections correct?
2. Is the mechanism being operated correctly?

If the mechanism does not operate correctly, check the items listed in the table below. Should the problem persist, there may be a malfunction. If this is the case, disconnect the mains power immediately and contact your installer

Symptom	Cause	Remedy	Page
Mechanism not working (Check flashing light on control box)	Remote control or batteries faulty	Replace batteries or remote, to check batteries view controller through a camera screen and press buttons, controller light should be visible	14
	Motor end stops incorrectly set	Adjust end stop	9
Contact closure not working	Incorrect pin configuration	Terminate 8-pin RJ45 to 568/b pin configuration	12
	Faulty wiring	Replace connector or cable	13
	Faulty control box	Test contact closure on control box	13
RS232 not working	Incorrect settings	Refer to instructions	14
	Incorrect pin configuration	Terminate 6-pin RJ11 to configuration supplied	13
	ASC11 protocol error	Amend Protocol	13

PIC SP - Picture Split Mechanism



Test Motor Operation

If the mechanism is not working, it is possible to test the motor directly. To do so, locate and open the control box.

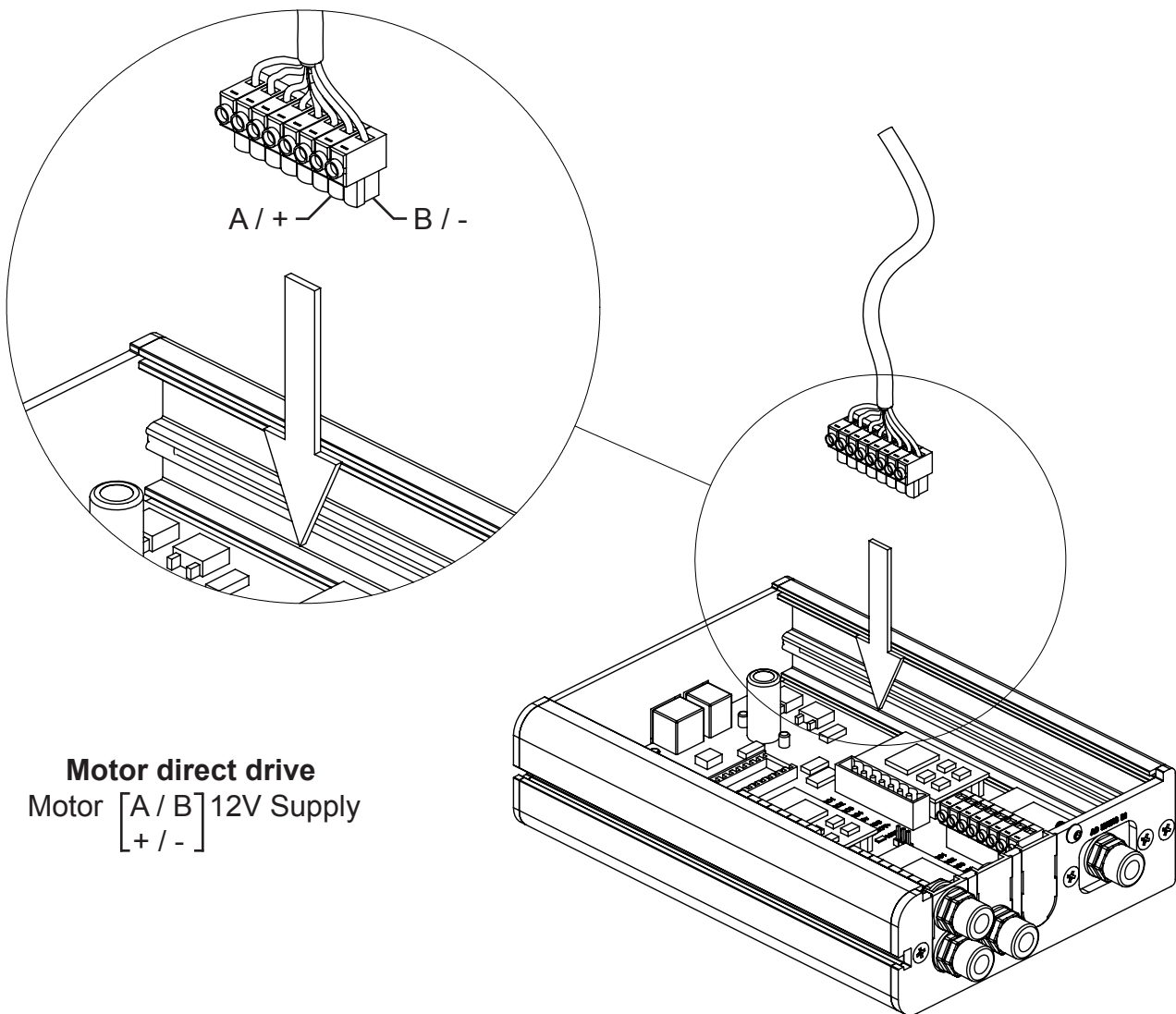

Motor direct drive
Motor [A / B] 12V Supply
[+ / -]



CAUTION. Apply mains voltage taking all necessary grounding precautions.

PIC SP - Picture Split Mechanism



A general technical overview of the PIC SP1, 2 & 3 picture split mechanism.

	PIC SP1	PIC SP2	PIC SP3
Product Dimensions (W,D,H)	1430x50x660mm [56.3x2x26"]	1680x50x660mm [66.1x2x26"]	1930x50x940mm [76x2x37"]
Weight (Kg)	24Kg [52.9lb]	25Kg [55.1lb]	27Kg [59.5lb]
Power Consumption	110W	110W	110W
Power Consumption On Standby	3W	3W	3W
Lifting Capacity (Kg)	10Kg [22.0lb]	10Kg [22.0lb]	10Kg [22.0lb]
Standard Colour	BLACK	BLACK	BLACK
Picture Movement	1150mm [45.3"]	1400mm [55.1"]	1650mm [65"]
Control	IR Remote, RS232 & Contact Closure	IR Remote, RS232 & Contact Closure	IR Remote, RS232 & Contact Closure
Power Supply	240V or 110V	240V or 110V	240V or 110V
Control Of 3rd Party Product	Yes	Yes	Yes
Output Power Supply	12V - 240V	12V - 240V	12V - 240V
Control Box Size (W,D,H)	150x150x52mm [5.9x5.9x2"]	150x150x52mm [5.9x5.9x2"]	150x150x52mm [5.9x5.9x2"]
Shipping Details X2 Boxes			
Dimensions (W,H,D)	800x800x150mm [31.5x31.5x5.9"]	1000x800x150mm [39.4x31.5x5.9"]	1100x1100x150mm [43.3x43.3x5.9"]
Weight (Kg)	14.5Kg [32lb]	15Kg [33lb]	16Kg [35.3lb]

PIC SP - Picture Split Mechanism



Notes...



Future Automation

Unit 2 Kimpton Enterprise Park
Claggy Road
Kimpton
Hertfordshire
SG4 8HP
United Kingdom

Tel: +44 (0) 1438 833 577

Fax: +44 (0) 1438 833 565

Email: info@futureautomation.co.uk

www.futureautomation.co.uk