

# Installation Instructions

## SPS 800 / 1200 - Sliding Panel Mechanism with Screen Advance

### Design Highlights

- Range of Single Panel and Split Panel Options
- Space Efficient Design
- Wide Range of Cabinetry and Wall Design Options
- Unique Functionality

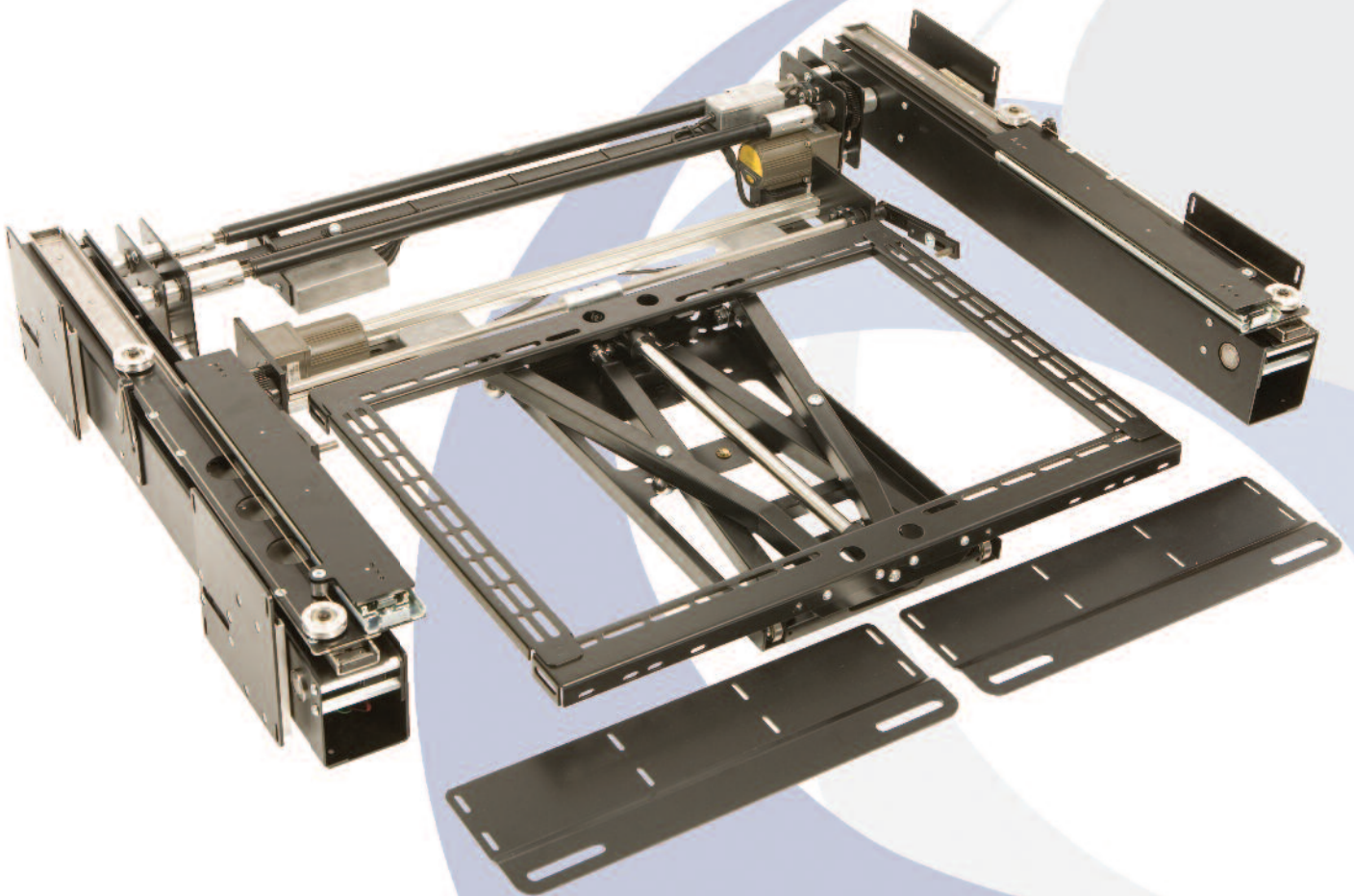

Thank you for choosing  
**futureautomation**

# SPS 800 / 1200 - Sliding Panel Mechanism with Screen Advance



Caution  
Warning



Beware of  
Moving Parts



Danger  
Electricity



Keep Hands  
Clear

## Safety Disclaimer

Important Safety Instructions

Explanation of graphical symbols

-(Electric Shock Symbol) = The lightning flash within an equilateral triangle is intended to alert you to the presence of un-insulated "dangerous voltage" within the products enclosure that may be of sufficient magnitude to constitute an electric shock to persons

-(Caution Symbol) = The exclamation point within an equilateral triangle is intended to alert you to the presence of important operating and maintenance (servicing) instructions in the literature accompanying the product

-(Tools Symbols) = The tools symbol within a coloured square are intended to highlight the required tools necessary for correct and safe installation of the product. These are intended as a guide only, and it is at the installer's discretion as to which tools are used.

**WARNING: RISK OF ELECTRIC SHOCK, ONLY AUTHORIZED INSTALLERS TO OPEN THE POWER CONTROL BOX.**

**WARNING:** To reduce the risk of fire or electric shock, do not expose electrical parts to rain or moisture, unless the product has been specifically designed to do so.

**WARNING:** Failure to provide adequate structural strengthening, prior to installation can result in serious personal injury or damage to the equipment. It is the installer's responsibility to ensure the structure to which the component is affixed can support the four times the weight of the component.

**WARNING:** Do not exceed the weight capacity. This can result in serious personal injury or damage to the equipment. It is the installer's responsibility to ensure that the total combined weight of all attached components does not exceed that of the maximum figure stated.

**WARNING:** Failure to provide adequate structural strength for this component can result in serious personal injury or damage to equipment! It is the installer's responsibility to make sure the structure to which this component is attached can support five times the combined weight of all equipment. Reinforce the structure as required before installing the component.

## Warnings:

1. **Read all technical instructions fully before installation and use. It is the installer's responsibility to ensure that all documentation is passed on to the end user and read fully before operation.**
2. **Keep all documentation.**
3. **Heed all warnings.**
4. **Follow all technical specifications and instructions during installation.**
5. **Do not use near water unless the product has been specifically designed to do so.**
6. **Clean only with a dry cloth.**
7. **Do not defeat the purpose of the polarized or grounding type plug. A polarized plug has two blades, one wider than the other. A grounding type plug has two blades and a grounding prong. The wide blade or third prong are provided for your safety. If the provided plug does not fit your outlet, consult an electrician or contact the manufacturer.**
8. **Protect the power cord from being walked on or pinched, particularly at plugs, convenience receptacles, and the point where the exit from the apparatus.**
9. **Unplug the apparatus during lightning storms or when unused for long periods of time.**
10. **Only use attachments/accessories specified by the manufacturer.**
11. **Refer all servicing to qualified personnel. Servicing is required regularly on an annual basis, when the apparatus is damaged in any way, liquid has been spilled or objects have fallen into the apparatus, the apparatus has been exposed to rain or moisture, does not operate normally, or has been dropped.**
12. **To completely disconnect the apparatus from the AC mains, disconnect the power cord plug from the AC receptacle on the power control box.**
13. **To prevent overheating, do not cover the apparatus. Install in accordance with the instructions.**
14. **UK, Ireland and Hong Kong only – The power cord is supplied with a 13A plug having an earthing pin. The apparatus is earthed and this pin is not required for safety, merely to operate the safety shutter of mains outlet.**
15. **No naked flames such as lit candles should be placed on the unit.**
16. **Observe and follow the local regulations when disposing of batteries.**
17. **Do not expose the unit to dripping or splashing fluids.**
18. **Do not place objects filled with liquid, such as vases, on the unit.**
19. **Do not expose the batteries to excessive heat such as sunshine, fire or the like.**
20. **For all mounted apparatus, the apparatus should be installed on solid wood, bricks, concrete or solid wood columns and battens.**
21. **Always turn off power at source before putting on or taking off parts and cleaning.**
22. **Do not use outdoors unless marked for outdoor use.**
23. **Exceeding the weight capacity can result in serious personal injury or damage to equipment.**

Future Sound & Vision trading as Future Automation intend to make this and all documentation as accurate as possible. However, Future Automation makes no claim that the information contained herein covers all details, conditions or variations, nor does it provide for every possible contingency in connection with the installation or use of this product. The information contained in this document is subject to change without prior notice or obligation of any kind. Future Automation makes no representation of warranty, expressed or implied, regarding the information contained herein. Future Automation assumes no responsibility for accuracy, completeness or sufficiency of the information contained in this document.

# SPS 800 / 1200 - Sliding Panel Mechanism with Screen Advance

<b>Contents</b>	<b>Page</b>
Introduction	
Safety Information	1
Contents	2
Contents	3
Tool Indicator Icons	3
Installation	
Parts List	4
Package Contents	4
Stage 1	
Before you Begin 1	5
Preliminary Checks	5
Stage 2	
Before you Begin 2	6
Electrical Connections	6
Stage 3	
Mark the Screen Position in the Enclosure	7
Stage 4	
Positioning the Moving Panel Mechanism	8
Stage 5	
Fitting the Moving Panel Mechanism	9
Stage 6	
Fitting the Drive Unit	10
Stage 7	
Screen Advance Option	11
Option A - Screen Positioning	11
Stage 8	
Option A - Mounting the PS Bracket to the Wall	12
Stage 9	
Option A - Mounting the Screen Advance Unit	13
Stage 8	
Option B - Screen Positioning	14
Stage 9	
Option B - Mounting the Screen Advance Heavy Unit	15
Stage 10	
Connecting the Mechanisms	16
Stage 11	
Fit the Mount Plate	17
Stage 12	
Fit the Front Panel and Moving Panel	18
Stage 13	
Fitting the Screen	19
Stage 14	
Panel Up Adjustment	20
Stage 15	
Panel Down Adjustment	21

# SPS 800 / 1200 - Sliding Panel Mechanism with Screen Advance

Electrical Connections	
Contact Closure	22
RS232	23
Operation Details	23
Operations	
IR Control	24
IR Operation Buttons	24
Changing Batteries	24
Trouble Shooting	25
Technical Overview	25
Notes	26

## Tool Indicator Icons

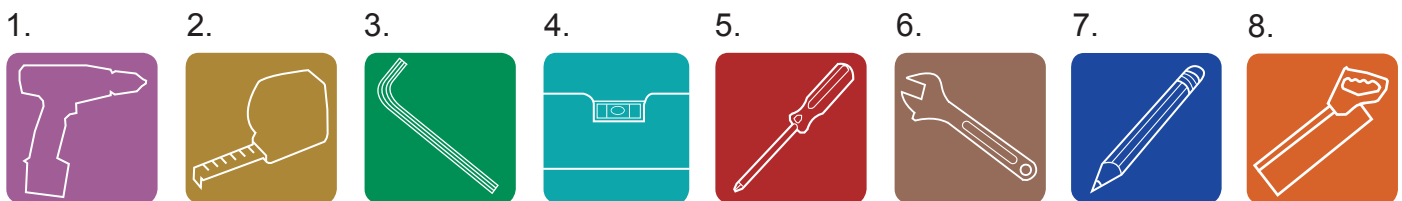

1. - Drill

2. - Tape measure

3. - Allen Keys

4. - Spirit Level

5. - Screwdrivers

6. - Spanners

7. - Pencil

8. - Saw

## Product Warranty

This product carries a warranty that covers the cost of labour and spare parts incurred by any defects in materials and workmanship under normal use during a two year period from date of purchase. Support for any problems that are not hardware faults are excluded from the warranty entitlement. This warranty does not affect your statutory consumer rights.

The following is excluded from warranty service:

- Malfunctioning caused by misuse or damage, accidental or otherwise, or service modification by persons not authorised by Future Automation, or the use of any non Future Automation supplied parts;
- Any electrical, or other environmental work external to your Future Automation mechanism including power cuts, surges or lightning strikes;
- Additional items not supplied by Future Automation although they may have been supplied together by the retailer;
- Any 3rd party software products controlling your mechanism;
- Any transfer of ownership. Warranty is provided only to the initial purchaser;
- Compensation for loss of use of the product, and consequential loss of any kind;
- Use of the product over the specified weight capacity;
- Any damage to products during transit that is not checked and notified as "unchecked" or "damaged" upon receipt of delivery.

Any part of your system that needs to be replaced during a warranty repair becomes the property of Future Automation.

# SPS 800 / 1200 - Sliding Panel Mechanism with Screen Advance

## Package Contents

- 1 - Panel Mechanism Right
- 2 - Panel Mechanism Left
- 3 - Panel Drive Unit
- 4a - Screen Advance Unit
- 4b - SPS PS Bracket
- 5 - Screen Advance Heavy Unit
- 6 - Panel Mount Plates
- 7 - Screen Advance Unit Rollers
- 8 - Side Runners
- 9 - IR Remote Control
- 10 - Control Box

## Not Shown On Page

- 11 - x2 AAA Batteries
- 12 - Multi Pack Of Nut, Bolts & Washers
- 13 - Mains Power & Other Leads

## Nuts & Bolts Multipack:

A range of nuts, bolts, washers and spacers to help add in the mounting for your screen

(Your pack may also contain a custom adapter if your screen is not VESA compatible)

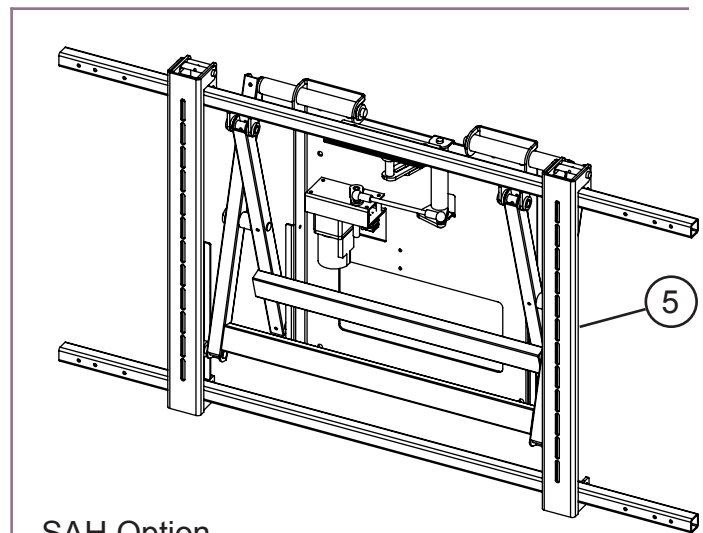
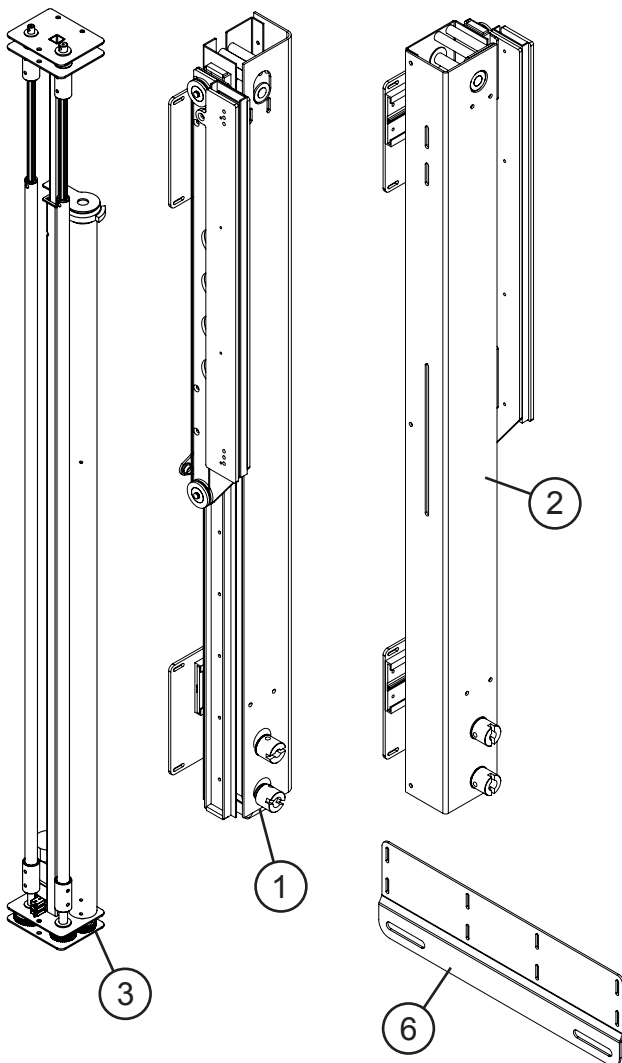
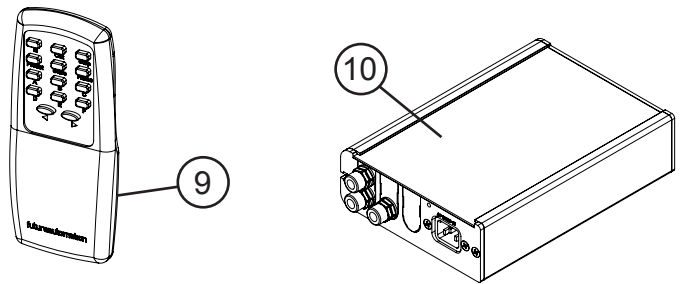

SAH Option

SA Option

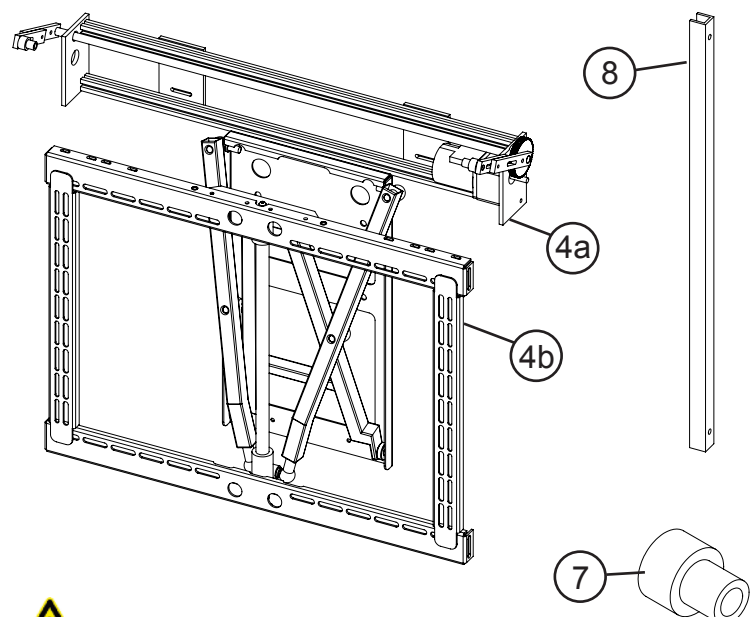

 (Parts not to scale)

 Only SA or SAH option will be provided



# SPS 800 / 1200 - Sliding Panel Mechanism with Screen Advance



## Before You Begin 1 Preliminary Checks

It is important to check various dimensions against the Technical sheet for this mechanism prior to starting the installation.

It is well worth setting up the mechanism out of the cabinet to familiarise yourself with the general operation.

Set up as shown. The panel drive unit shafts engage with the couplers on the panel mechanism. See detail A, right. The M5 x 35mm bolts connects them.

### NOTE:

Panel Advance Shaft rotates 180 degrees to create a forward-back motion of 40mm. If out of sync by 180 degrees it may jam.

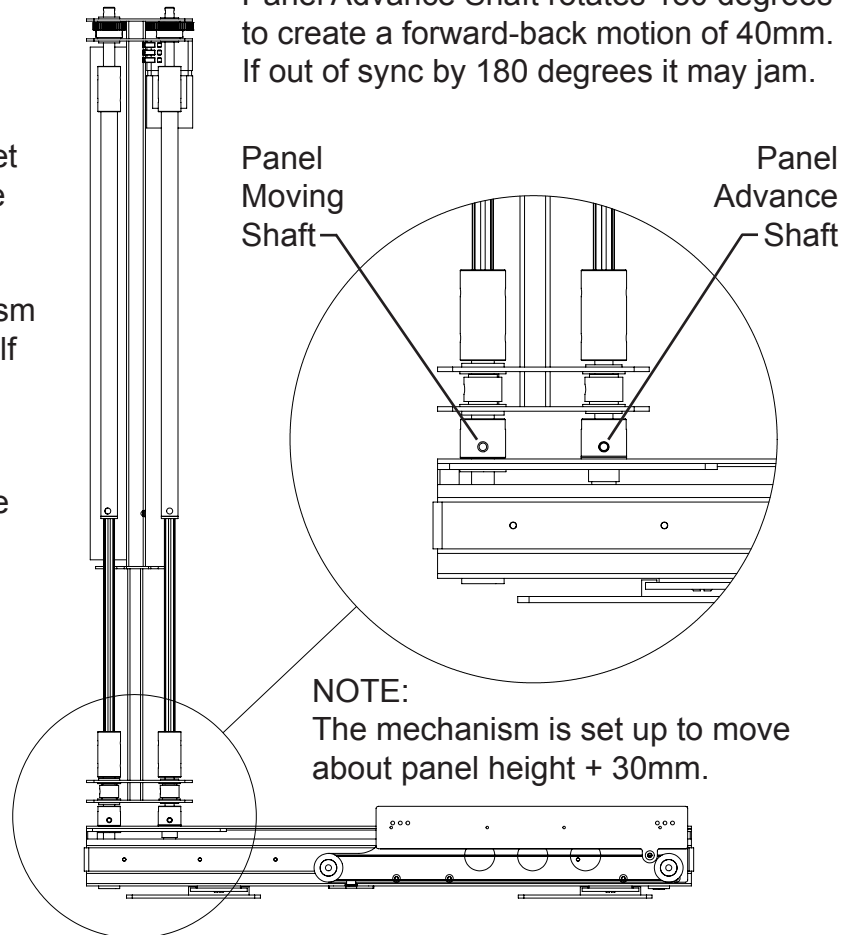

### NOTE:

The mechanism is set up to move about panel height + 30mm.

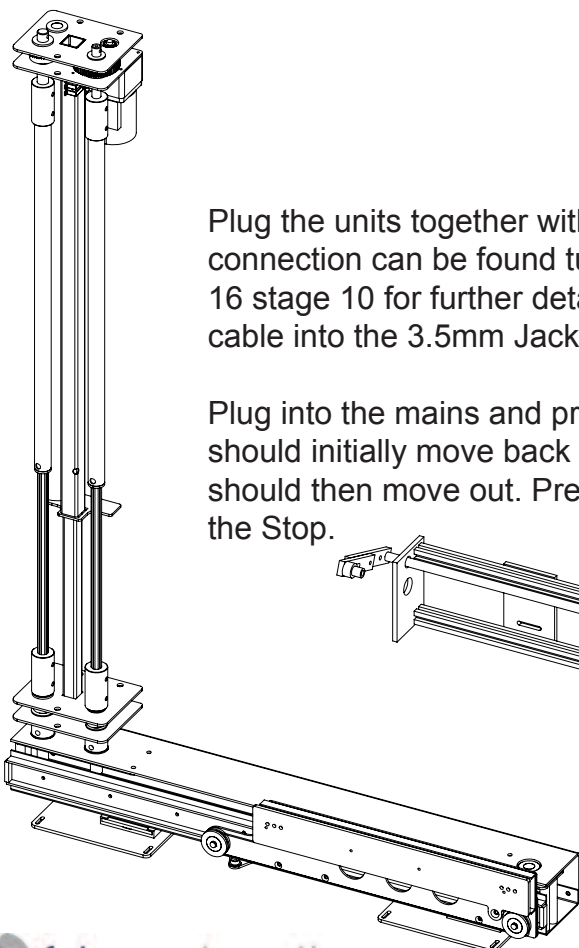

Plug the units together with the leads from the control box. The panel mechanism connection can be found tucked in one end of one of the mechanisms. See sheet 16 stage 10 for further details of the electrical connections. Plug the infrared receiver cable into the 3.5mm Jack connector.

Plug into the mains and press 'OUT' on the remote control. The panel mechanism should initially move back and then move off to the side. The plasma advance unit should then move out. Pressing 'IN' on the control reverses the operation. 'STOP' is the Stop.

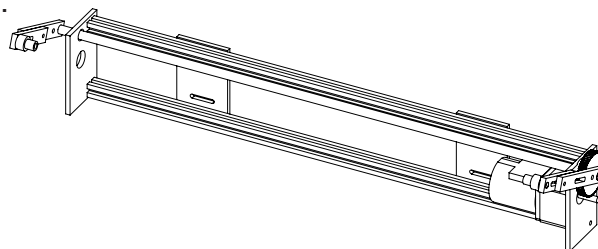

Do not adjust any of the cams on the mechanism. They are factory set to the correct positions. If you think you need to make adjustments to the cam please contact Future Automation first.

# SPS 800 / 1200 - Sliding Panel Mechanism with Screen Advance



## Before You Begin 2 Electrical Connections

The SPS 800 / 1200 mechanism must be connected to both the AC1, 2, 3 and DC1, 2 connection blocks. All connections must be made for the mechanism to fully function

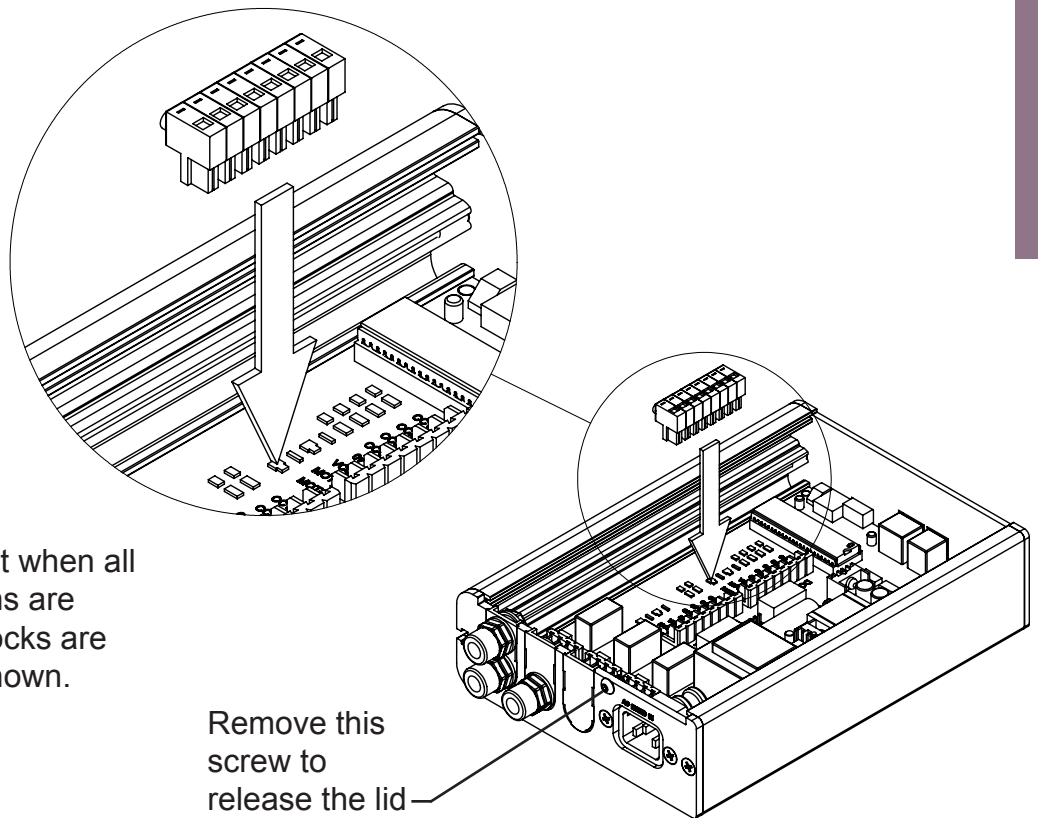

It is VERY important that when all the electrical connections are made, the connector blocks are connected in the way shown.

Connect the infrared sensor here

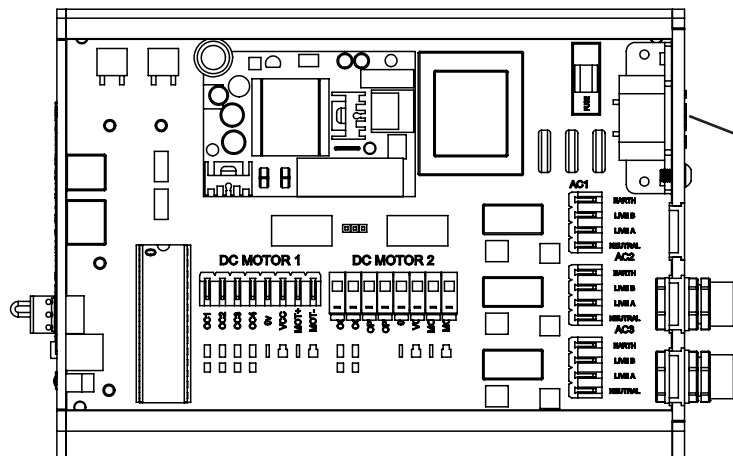
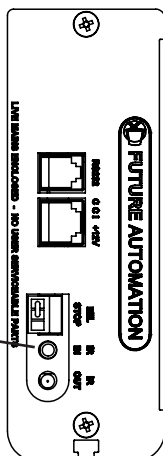



## Mark The Screen Position In The Enclosure

Firstly, mark where you intend the top of the plasma screen to be on the back wall of the enclosure.

Then mark a line showing where the centre of the screen / opening will be.

It may be helpful to mark out the outline of the whole plasma screen on the wall. This will help when positioning the moving panel mechanism.

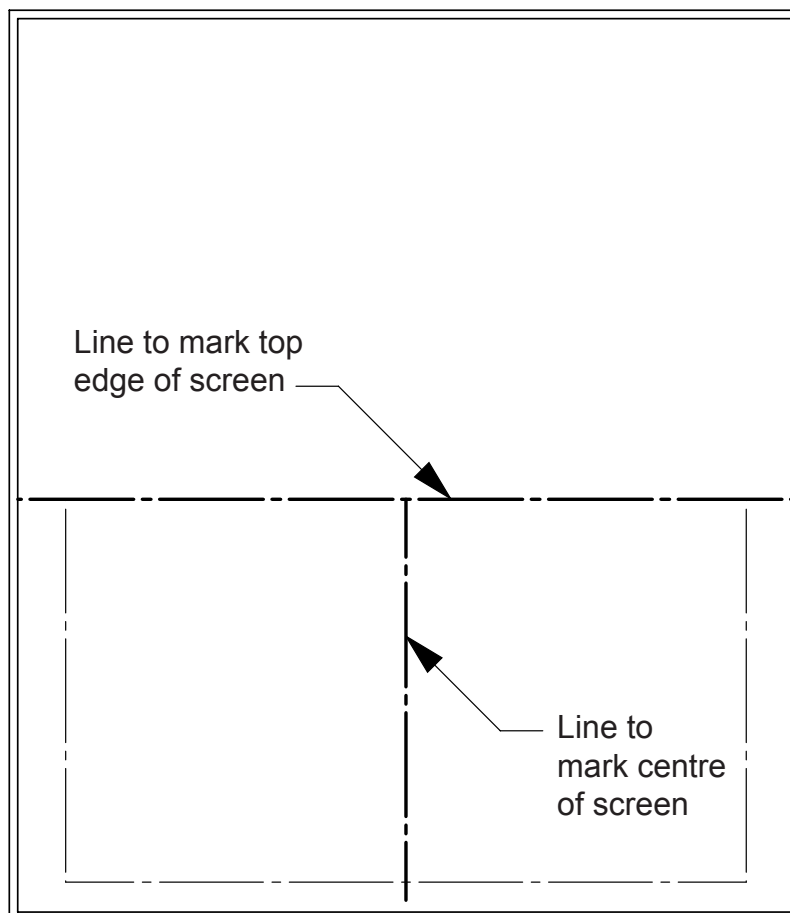
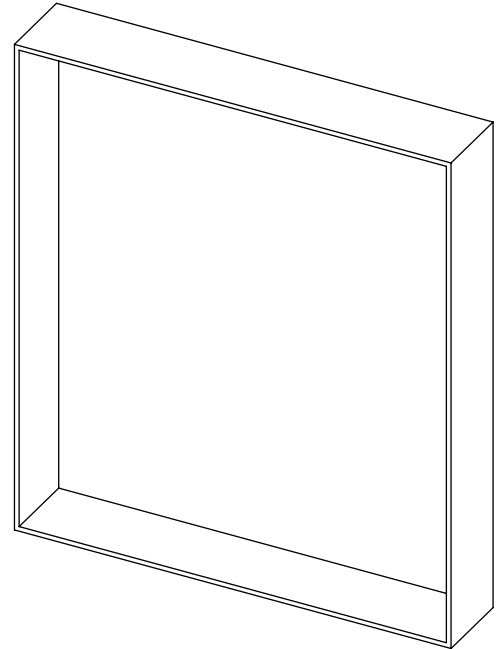



# SPS 800 / 1200 - Sliding Panel Mechanism with Screen Advance



## Positioning The Moving Panel Mechanism

Before the mechanisms can be fitted, it is important to decide on the exact positions where they need to be.

 Make sure that you have the mechanisms in the down and in position at this point.

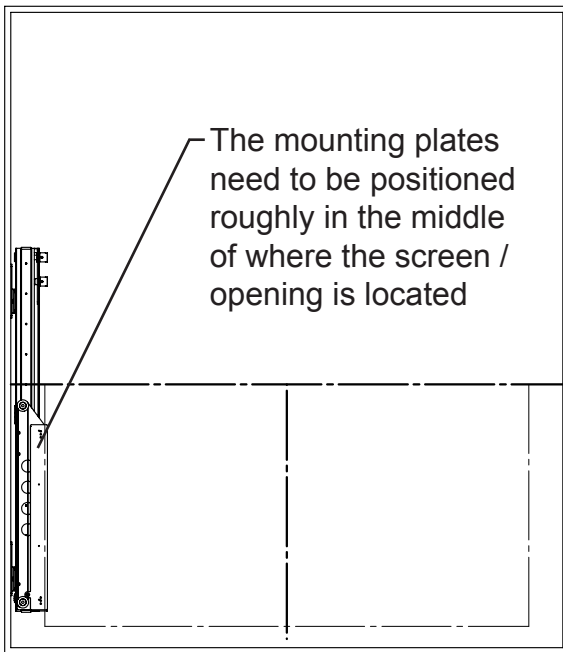

With the mechanism in place, measure the height that is needed to achieve this position.

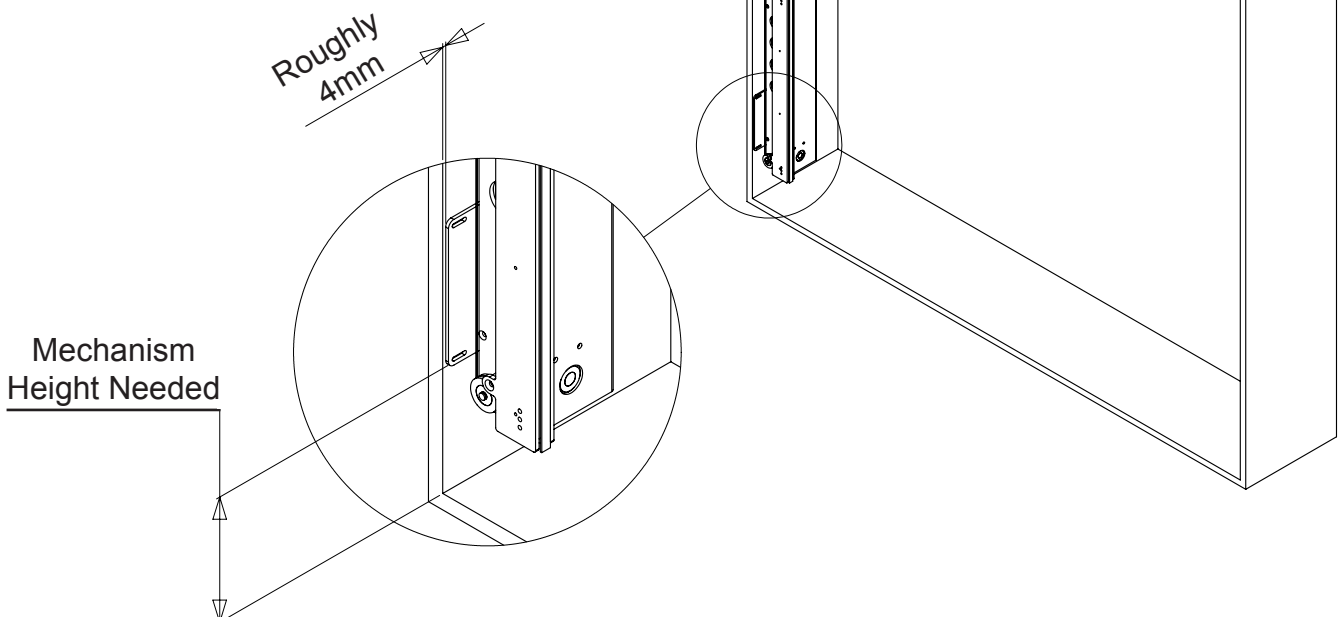



## Fitting The Moving Panel Mechanism

Before fixing the mechanisms, it is a good idea to cut a piece of wood to the size that you have just measured to provide the correct height. You can then sit both the mechanisms on the block of wood, knowing they should be the same height as long as the floor is level.



Make sure the mechanisms are level and parallel with each other before continuing.

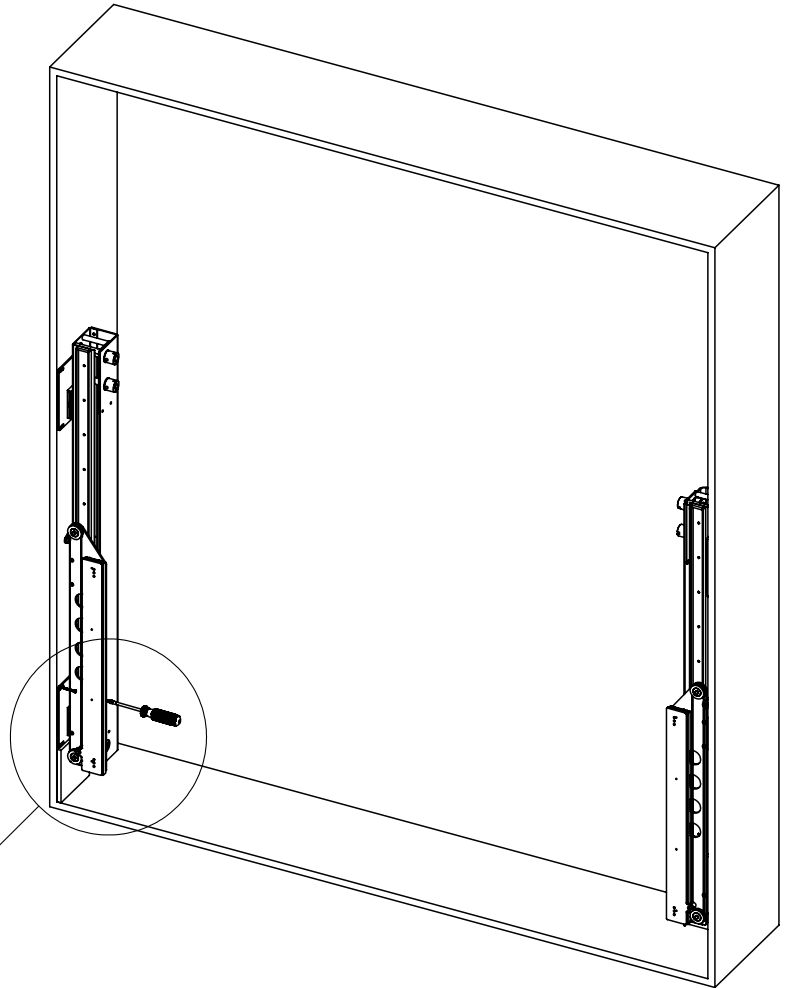

The moving panel mechanisms should be positioned roughly 4mm in from the edge of the enclosure.

Be sure to fix in the centre of the fixing slots to allow for adjustments at a later stage, use washers with screws.

Make sure to use the appropriate fixing type for the material you will be fixing to.

MDF block to help with installation

# SPS 800 / 1200 - Sliding Panel Mechanism with Screen Advance



## Fitting The Drive Unit

It is important that at this point both moving panel mechanisms are in the same down and in position.

The panel drive unit is a telescopic piece of equipment. Locate the 'motor end' of the unit in the two couplers at the top of the right hand moving panel mechanism.

Then extend the drive shafts of the unit until they locate in the couplers on the left hand moving panel mechanism.

Then use the M5 x 35mm bolts and nuts to secure the shafts in the couplers.

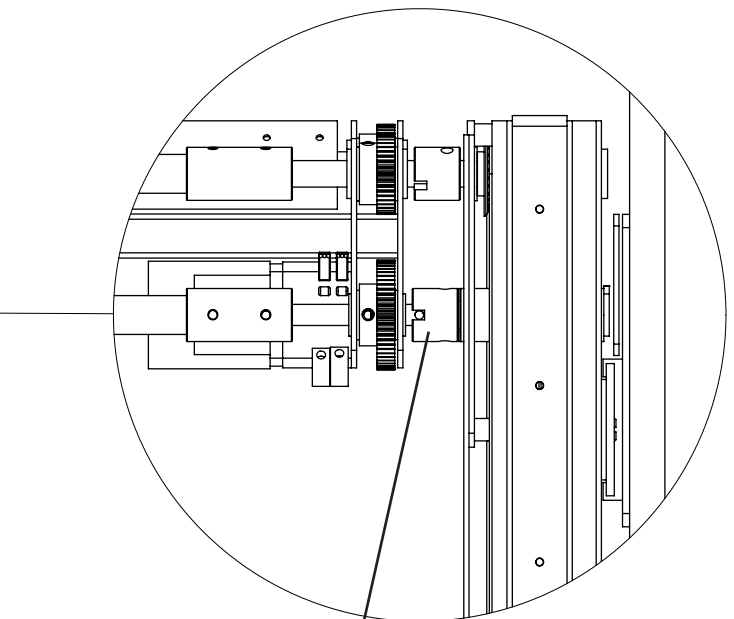
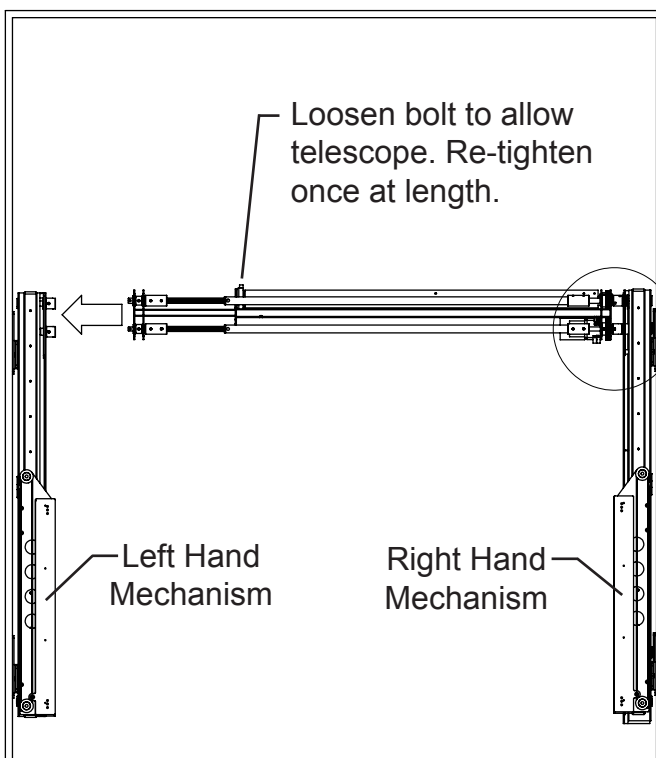
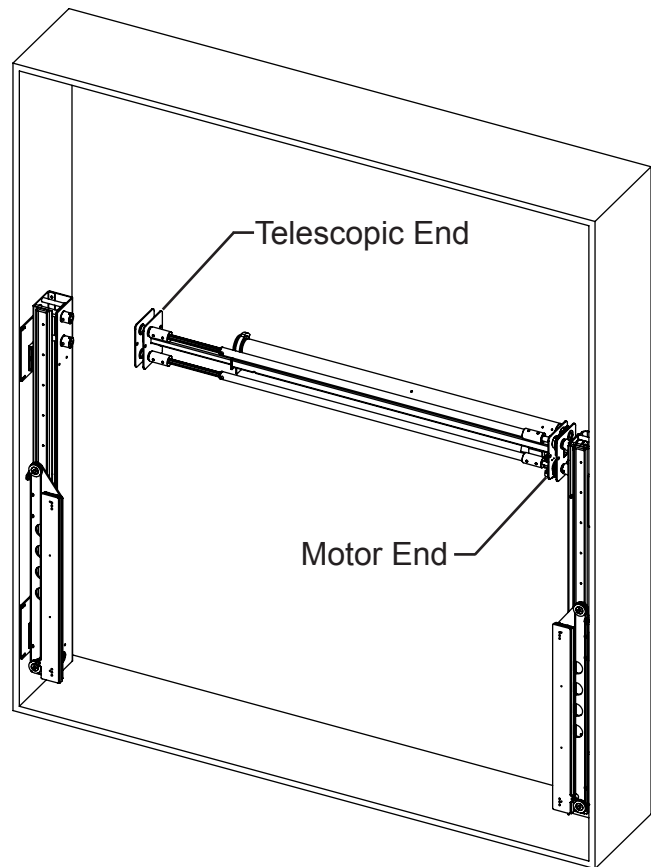

M5 x 35mm bolts with nuts through both these joints (both ends)

# SPS 800 / 1200 - Sliding Panel Mechanism with Screen Advance



## Screen Advance Options

Depending on the size of the screen will determine what screen advance unit will be supplied with the mechanism. Option A is the SA (Screen Advance) for smaller screens and option B is the SAH (Screen Advance Heavy) for large screens 60"+.

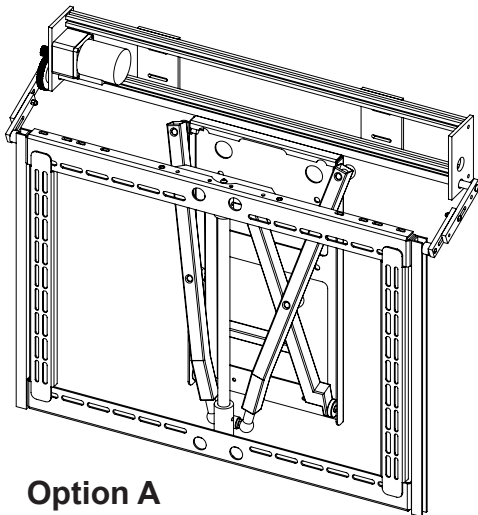

Option A

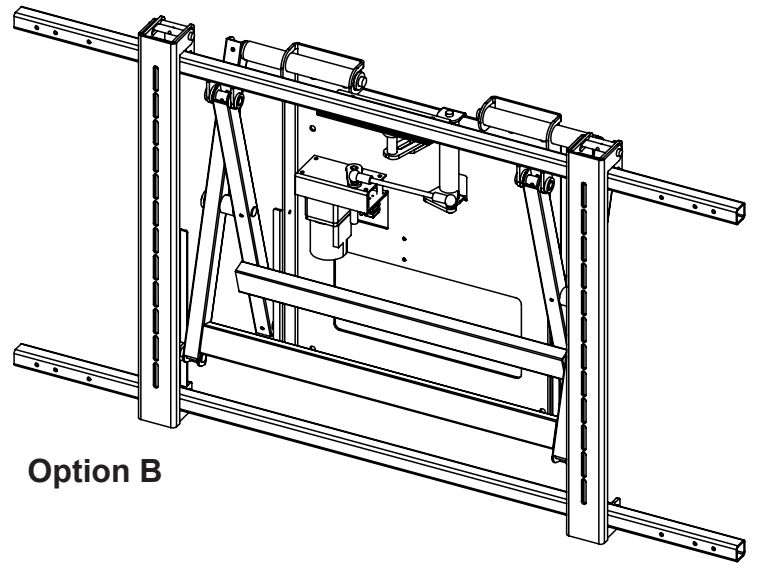

Option B

## Option A - Screen Positioning

Measure the distance from the top of the screen down to the centres of the two largest mounting holes in the PS Bracket wall plate.

Once you have made that measurement, remove the screen and prepare to fix the bracket to the wall or rear of the enclosure.

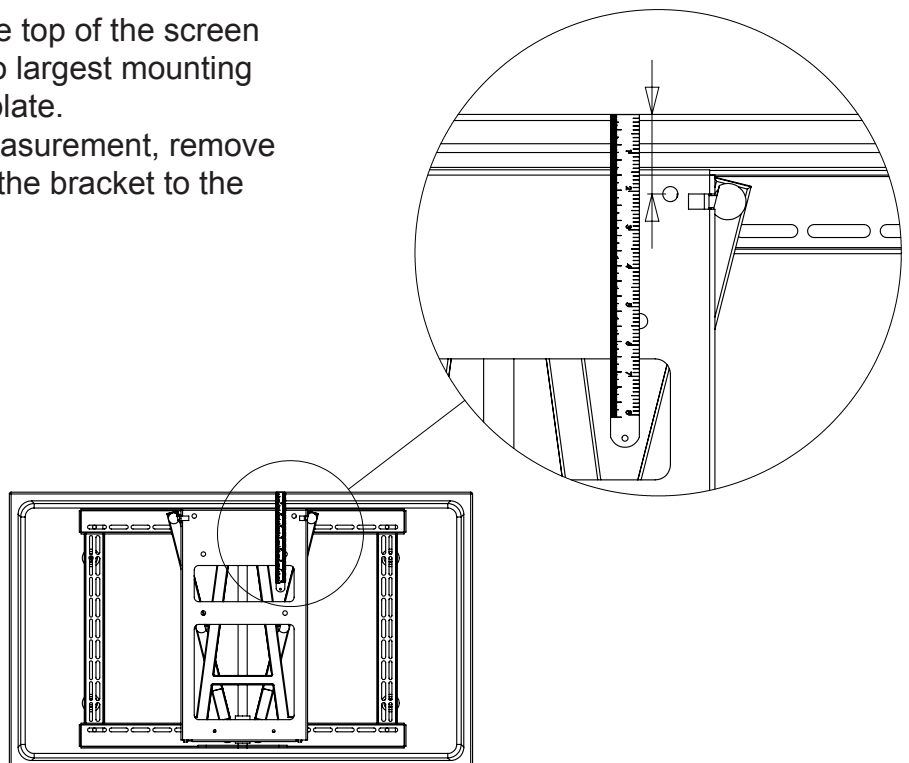

# SPS 800 / 1200 - Sliding Panel Mechanism with Screen Advance



## Option A - Mounting the PS Bracket to the Wall

Mark where the screen will be mounted on the wall and work out the positioning of the PS bracket on the back of the TV, this will save less adjustment later. Work from the top of the screen to the top of the PS bracket, horizontal dimension are shown below. Make sure the screen and mount are central in the aperture recess.

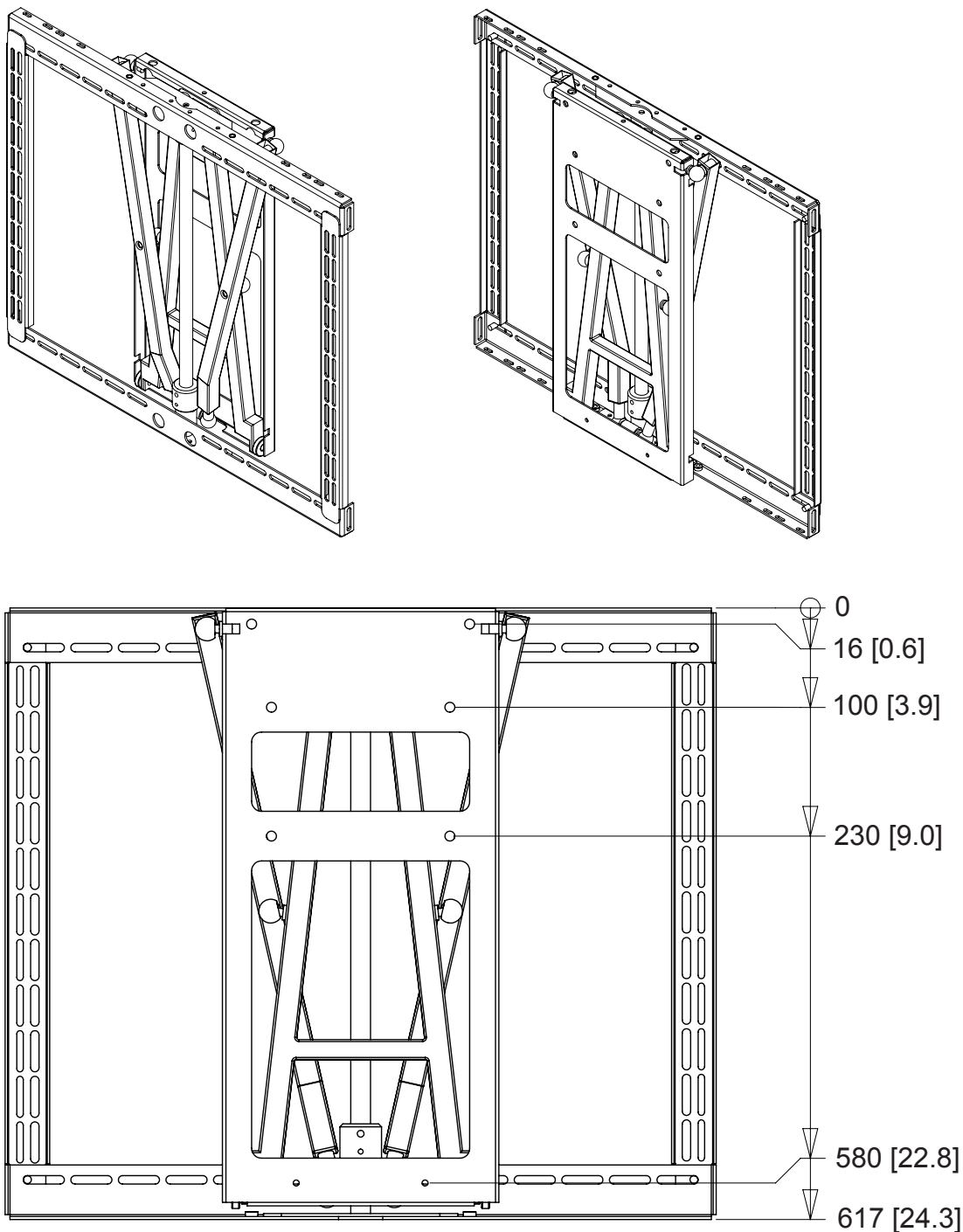

# SPS 800 / 1200 - Sliding Panel Mechanism with Screen Advance



## Option A - Mounting the Screen Advance Unit

Firstly, bolt the two side runners on to the sides of the PS bracket so that the arms of the Screen Advance Unit can slide up and down the channels.

Operate the Plasma Advance Unit so that it is in the 'OUT' position.

In the 'OUT' position, the rollers at the end of the arms should be just below the fixing bolts of the side runners on the PS bracket.

Do not rest the plasma advance unit on top of the PS bracket, as this will interfere with the bracket movement.

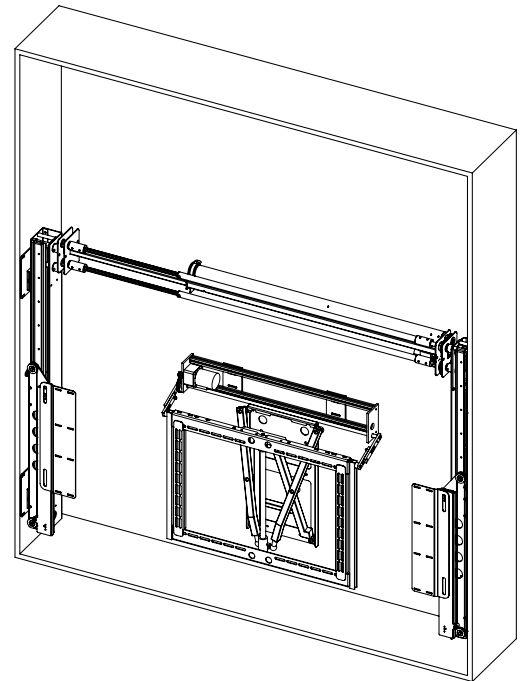

Side Runner X2

To adjust the SA advance distance loosen the nuts and bolts on the crank arms and slide longer or shorter.



Make sure to keep both arms the same length.

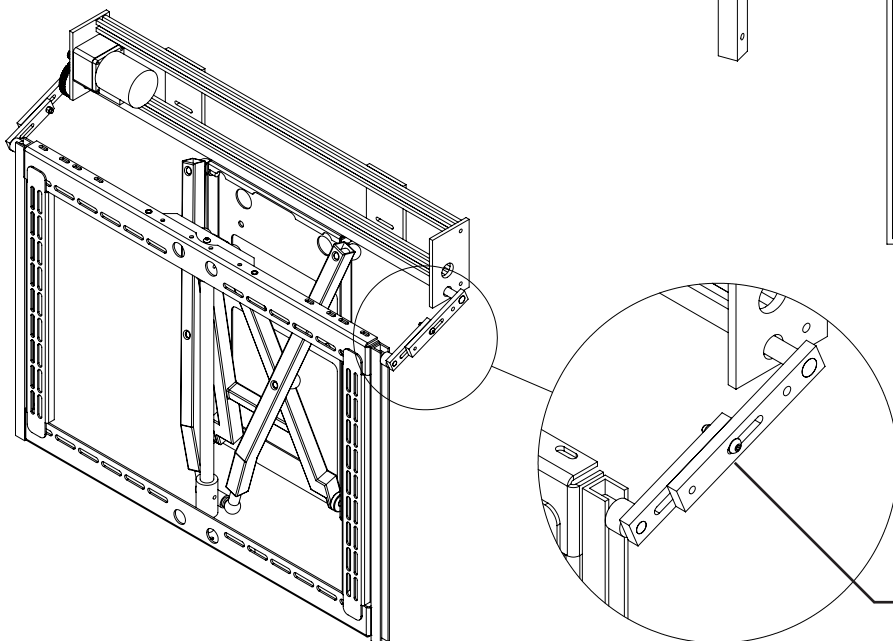
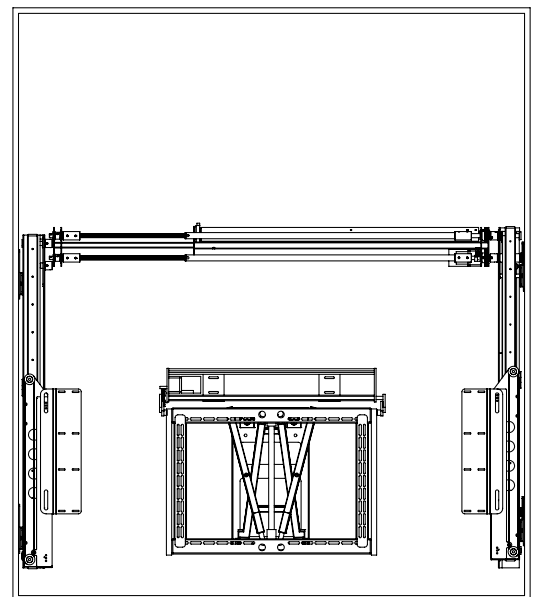



# SPS 800 / 1200 - Sliding Panel Mechanism with Screen Advance



## Option B - Screen Positioning

Measure the distance from the top of the screen down to the centres of the two largest mounting holes in the SAH Bracket wall plate.

Once you have made that measurement, remove the screen and prepare to fix the bracket to the wall or rear of the enclosure.

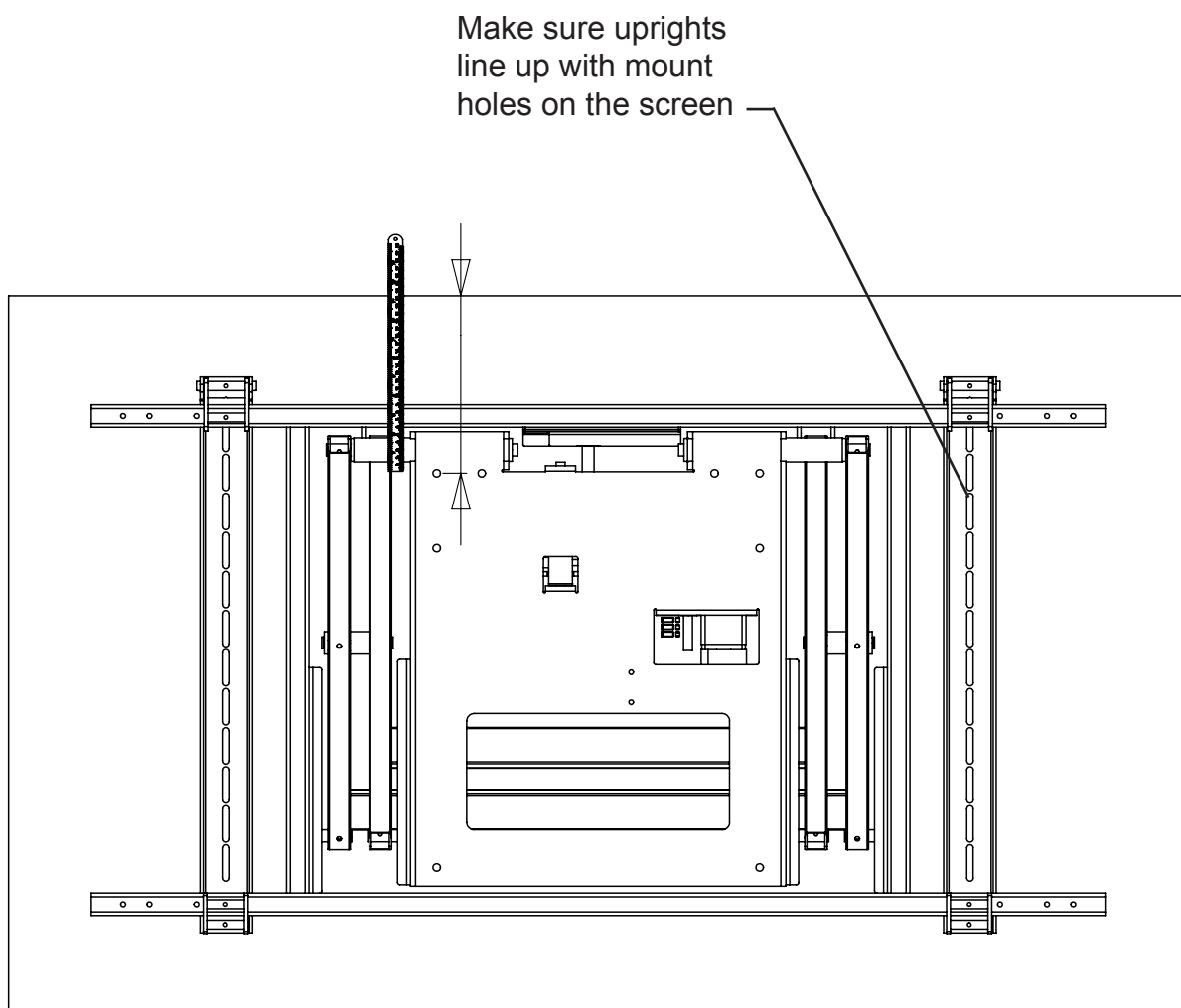

Image shows where to measure. From this measurement it is possible to determine where to drill the holes in the wall or rear enclosure.

# SPS 800 / 1200 - Sliding Panel Mechanism with Screen Advance



## Option B - Mounting the Screen Advance Heavy Unit

With the screen removed, offer the SAH unit into the enclosure and in the correct position. Fix securely in place and make sure the mechanism is square to the enclosure void.

Putting a packer under the SAH would help support the mechanism at the right height when securing to the rear face.

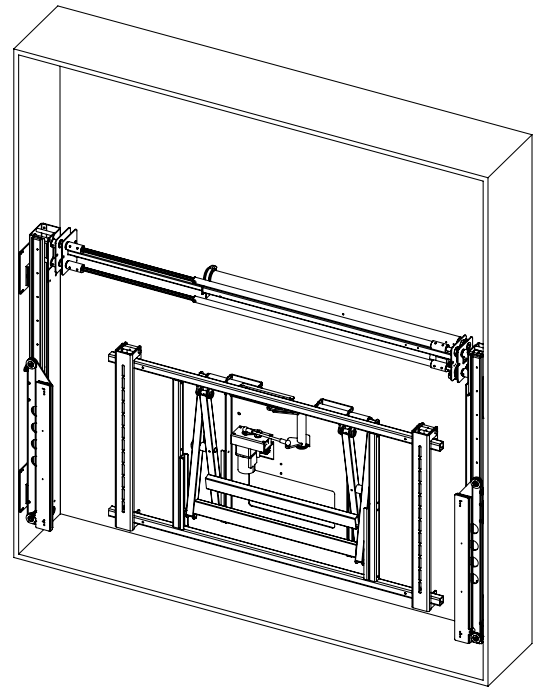
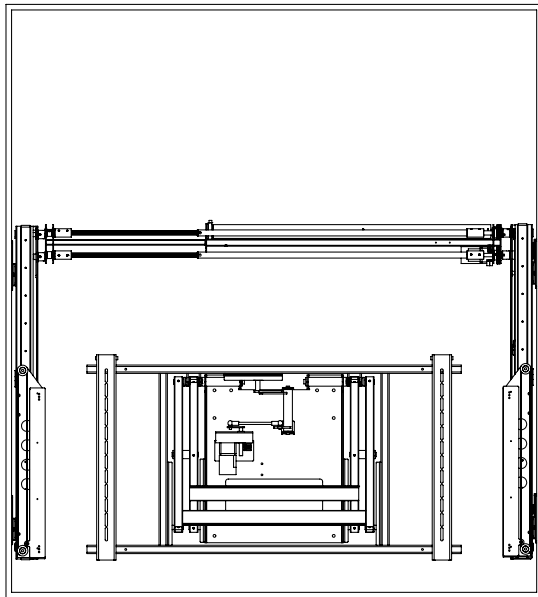

To adjust the SAH advance distance either slide the top mount plate on the slots or alter the crank length by loosening the bolts and slide longer or shorter. Finally you can adjust the distance by rotating the cams, adjust with caution.

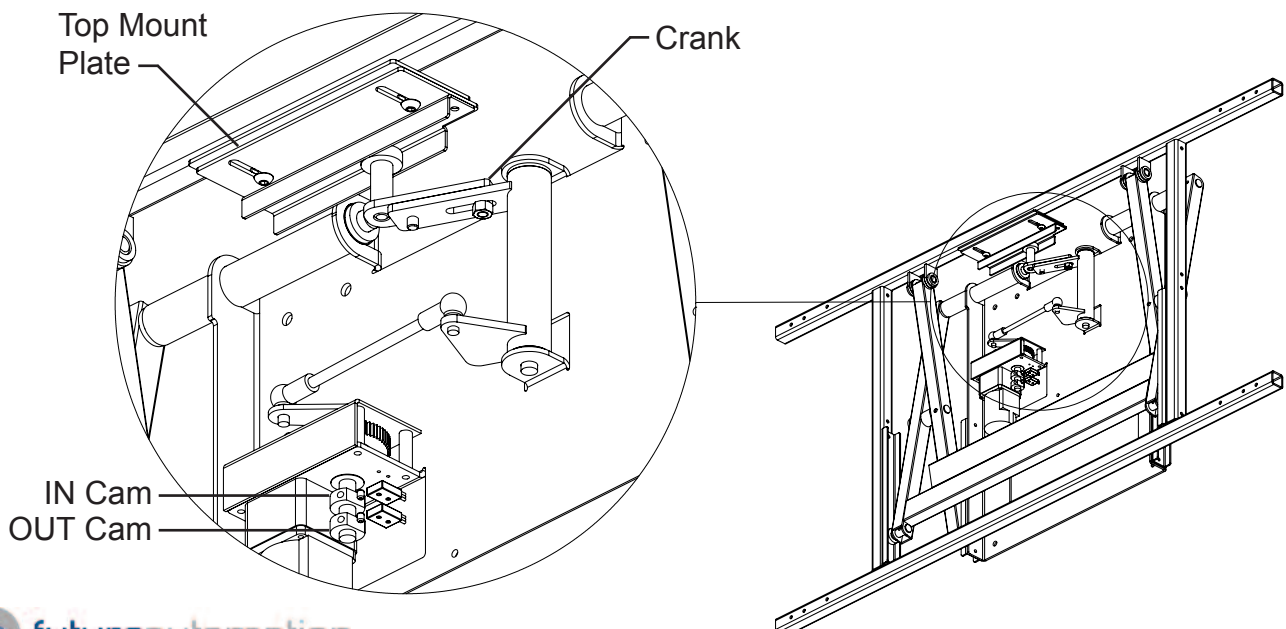

# SPS 800 / 1200 - Sliding Panel Mechanism with Screen Advance



## Connecting the Mechanisms

To connect the three mechanisms together electrically, is very simple.

To connect the Drive Unit to the Side Panels connect the 9 pin AMP plugs together labelled A to A.

Each mechanism has a set of wires coming from it. On the ends of the wires are control box inserts and block connectors.

These wires are marked with a label telling you which set of connectors the block connectors must go to.

The inserts then slide into the slots on the side of the control box.

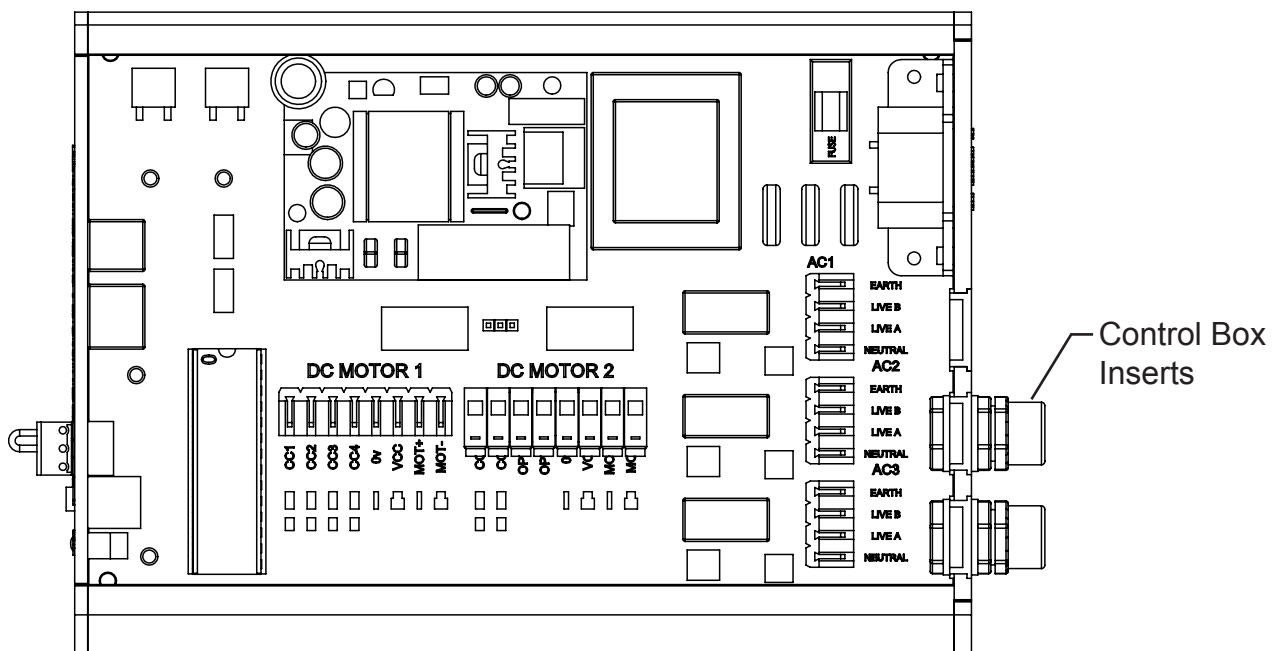
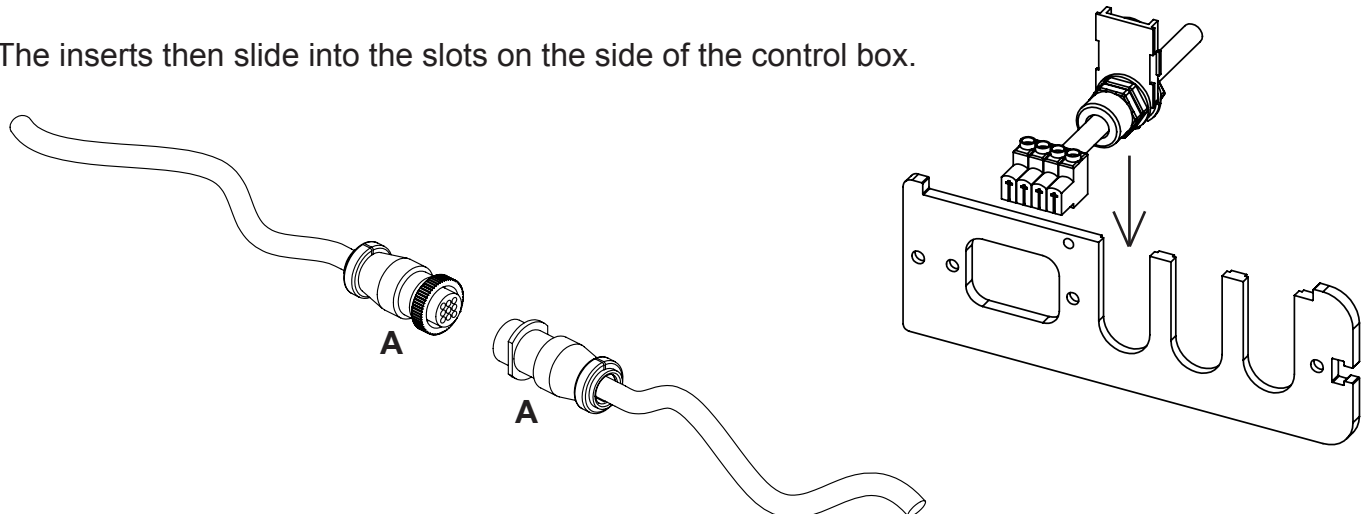

# SPS 800 / 1200 - Sliding Panel Mechanism with Screen Advance



## Fit the Panel Mount Plates

The mounting plates fix to the runners with M6 x 10mm CSK bolts with washers. There are a choice of 3 heights to fix the bolts on to. The large slot also allow for a lot of adjustability. Use 1 fixing in each slot.

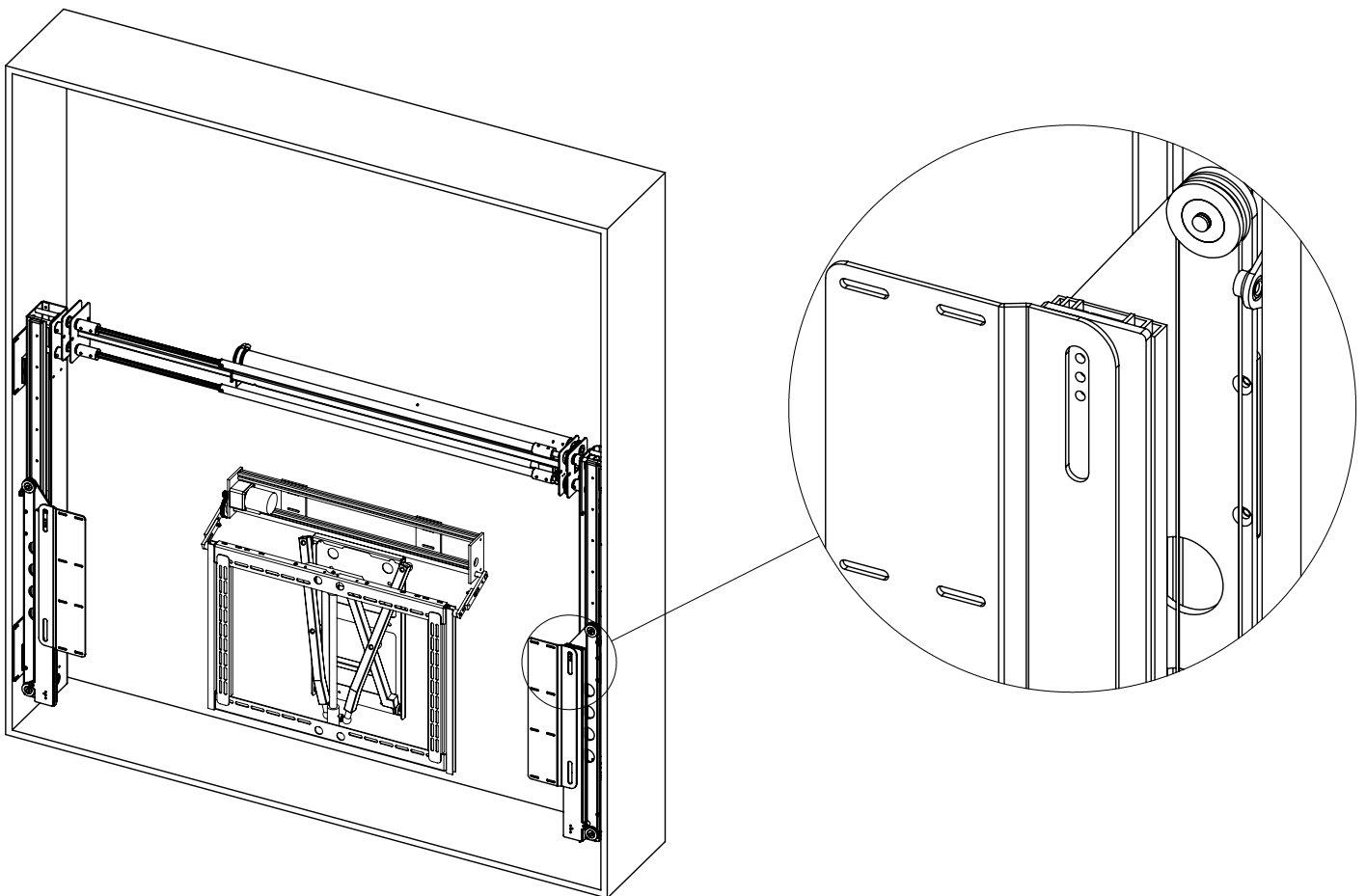

After fitting the mounting plates, it is a good time to set the mechanism is still operating correctly. Use the supplied IR remote to control the mechanism.

# SPS 800 / 1200 - Sliding Panel Mechanism with Screen Advance



## Fit the Front Panel and Moving Panel

Mounting Plate  
Height -5mm  
(Clearance)

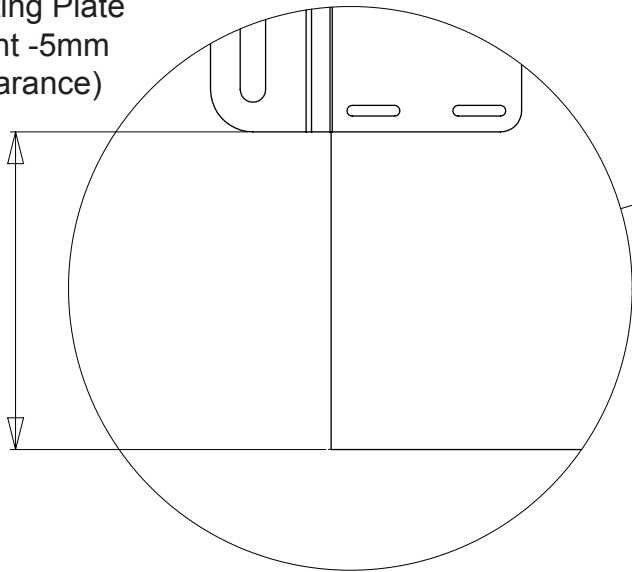

Fix the front panel to the enclosure. Measure the height of the panel mounting plates from the bottom of the opening.

Remove the moving panel and the panel mounting plates.

Then screw the panel mounting plates to the rear of the moving panel.

Then fix the moving panel to the mechanism by re-attaching the panel mounting plates.

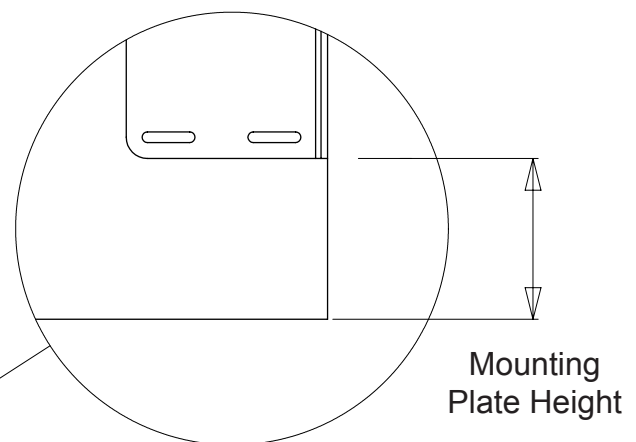
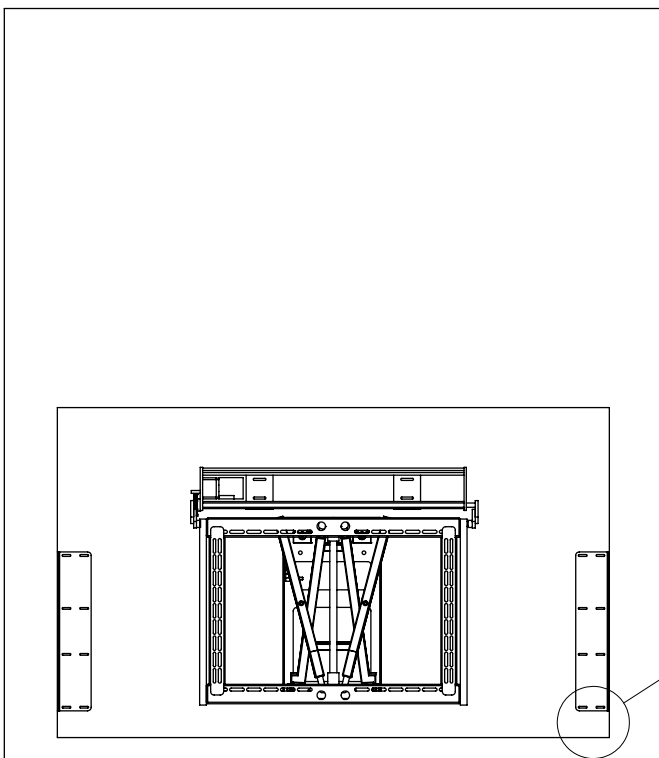

# SPS 800 / 1200 - Sliding Panel Mechanism with Screen Advance



## Panel Up Adjustment

To adjust the panel up position loosen the 2 bolts shown in the detail view. Do not fully remove them. Sliding the switch plate up will make the panel travel higher and sliding it down will travel less. The panel will travel approximately 3 times the distance the switch plate moves. Once desired height position is set tighten the bolts back up.

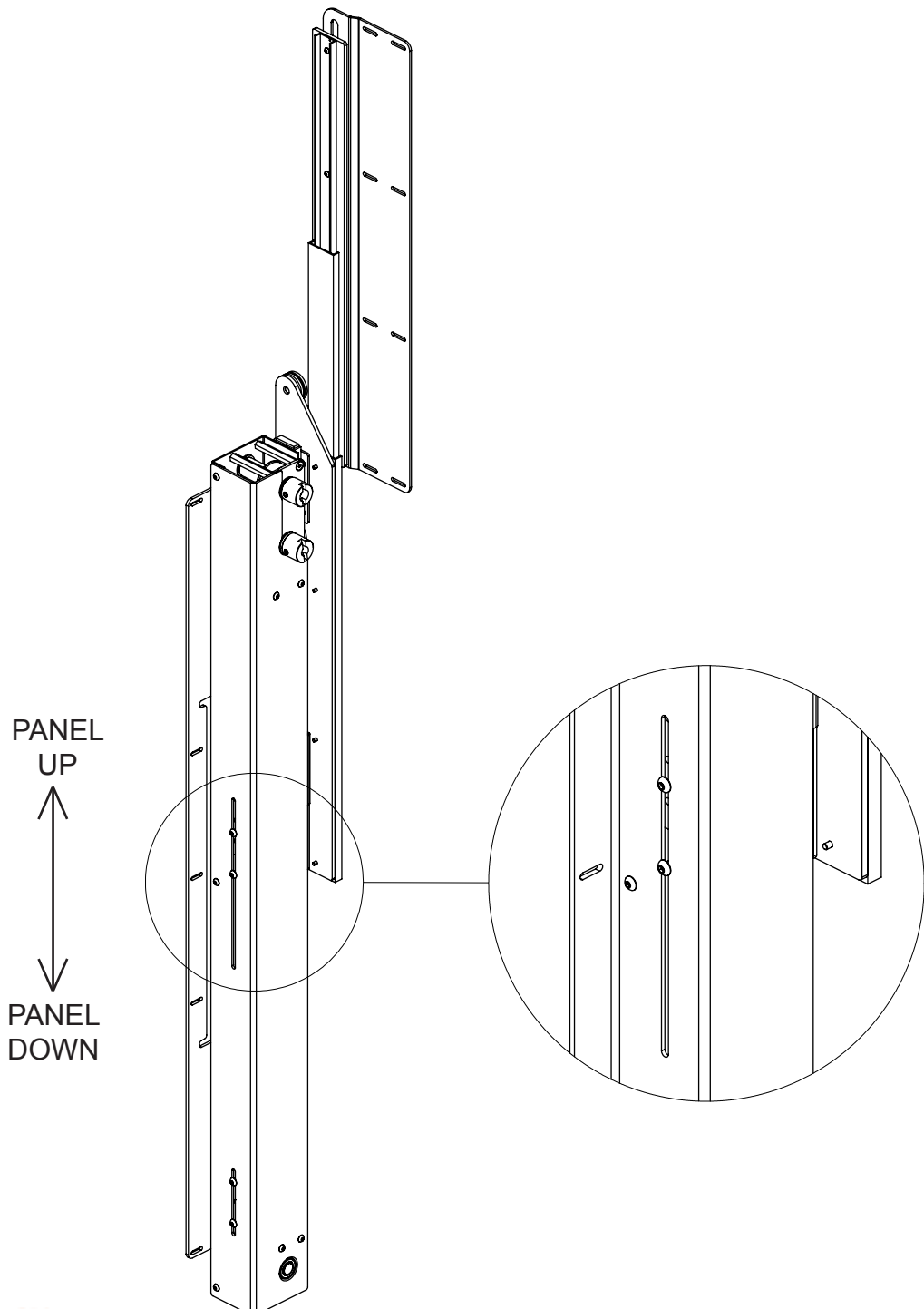



# SPS 800 / 1200 - Sliding Panel Mechanism with Screen Advance



## Panel Down Adjustment

To adjust the down position use the panel mount plate slots. There's 60mm [2.4"] of movement in the slot.

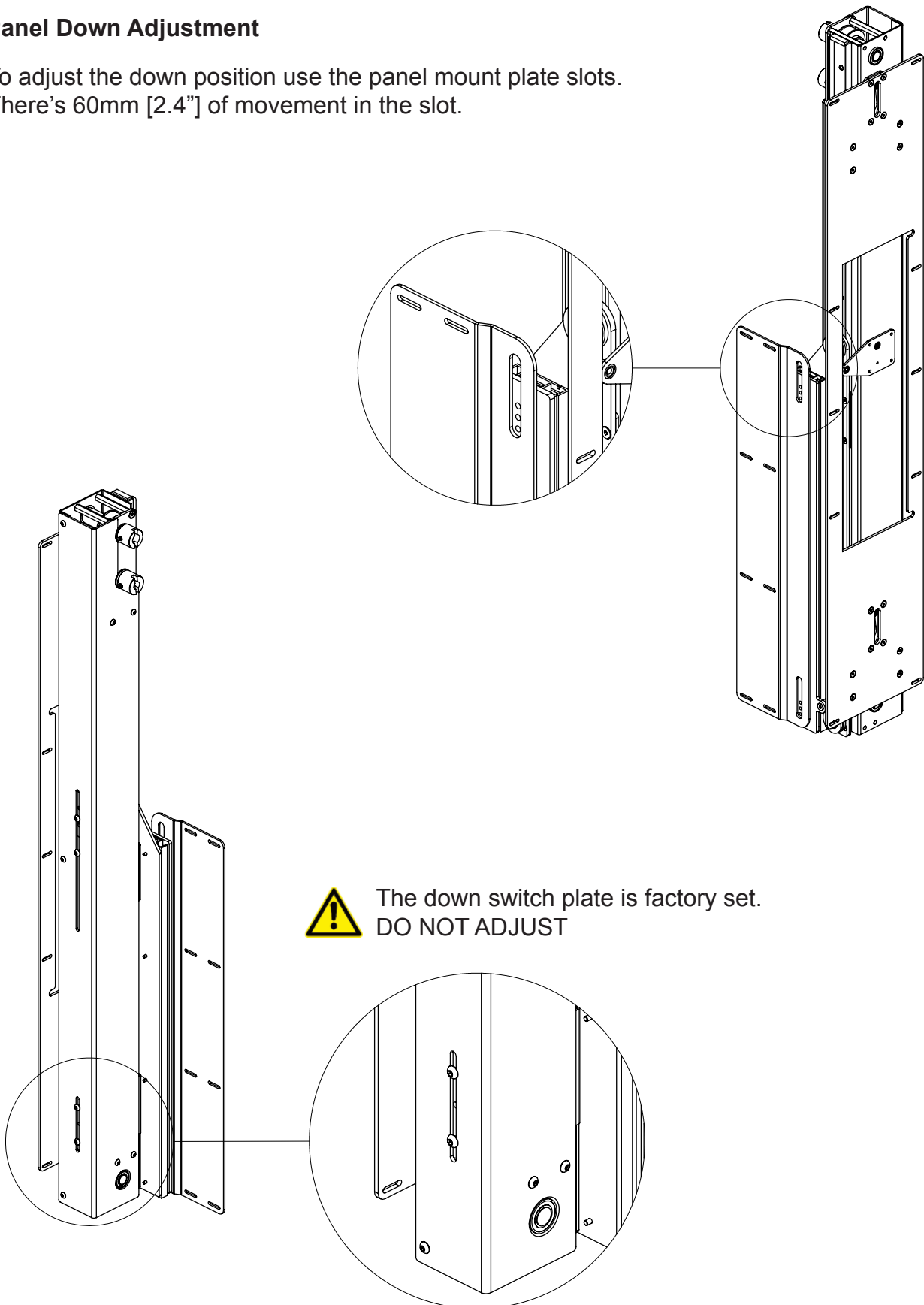



## Fitting the Screen

In order to fit the screen, the mechanism must be extended to its full reach. Press 'OUT' on the remote control and wait for the Screen Advance mechanism to reach its pre-set out position.

Once out, press 'B' on the remote control repeatedly to pulse the mechanism out until the frame is extended fully. The mechanism is now in a service mode.

Once extended, the frame can be manually pulled out further, so that the screen with uprights can be bolted to the frame.

Once the screen is bolted to the frame, the position of the screen may require some finer adjustment.

Adjustments can be made by altering the height the screen is fixed to the upright slot detail.

If more adjustment is still needed, remove the screen and make adjustments to the PS bracket adjusters, as shown earlier.

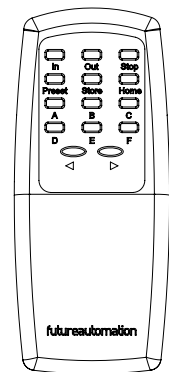
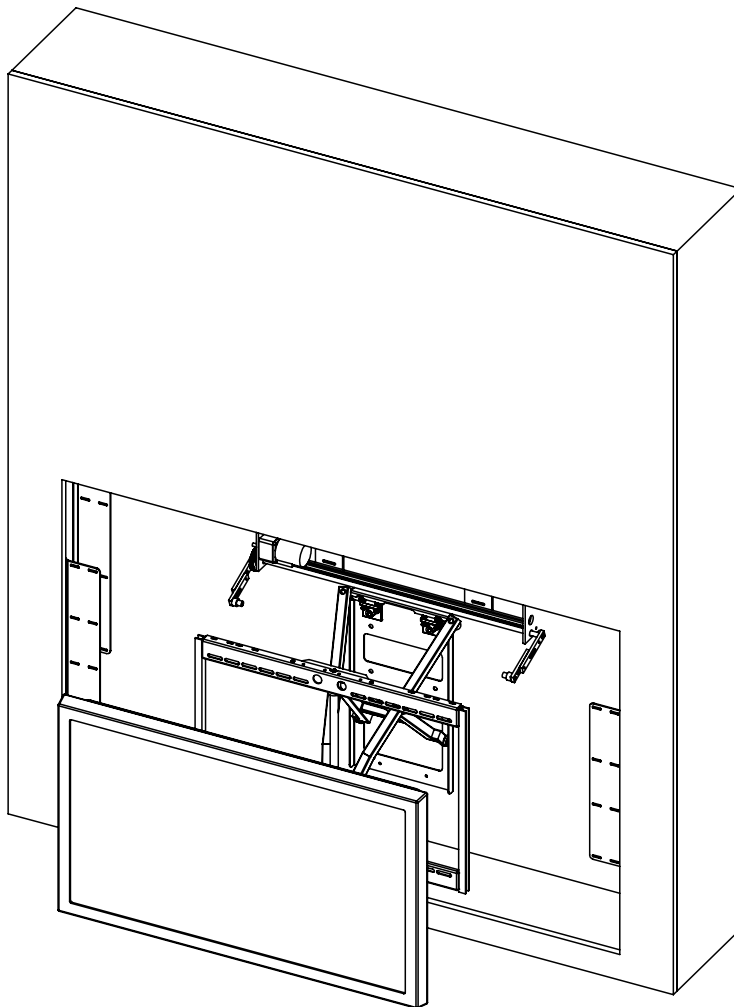

To return the mechanism from service mode to user mode, press 'A' repeatedly on the remote to pulse the frame work back in. Once the mechanism won't go back any further, wait for two seconds, and the mechanism is then in user mode.

# SPS 800 / 1200 - Sliding Panel Mechanism with Screen Advance



## Contact Closure

- Use an RJ45 connector in the CCI socket on the control box to operate via contact closure

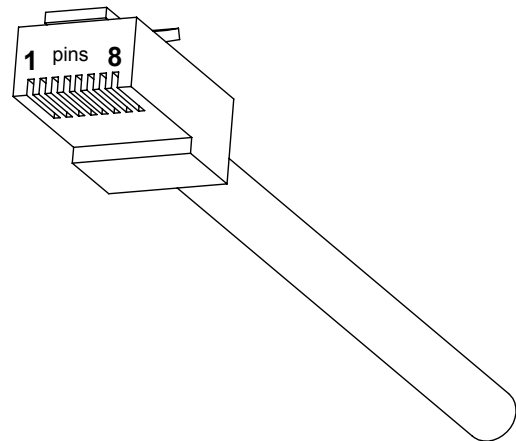

PIN	DESCRIPTION	ACTION	WIRE / CABLE		CONTACT CLOSURE LED INDICATOR
			568A	568B	
1	12V SUPPLY	12V SUPPLY - CURRENT LIMITED	W/G	W/O	
2	12V LATCH	When 12V attached, device will go OUT. When 12V removed, device will go IN.	G	O	
3	GROUND	GROUND	W/O	W/G	
4		PIN 4 NOT USED	BL	BL	
5	DEVICE LATCH	Short to GROUND (pin 3), device will go OUT, remove short device will go IN.	W/BL	W/BL	LED 4
6	DEVICE STOP	Momentary short to GROUND (pin 3), stops device in current position.	O	G	LED 3
7	DEVICE OUT	Momentary short to GROUND (pin 3), makes device go OUT.	W/BR	W/BR	LED 2
8	DEVICE IN	Momentary short to GROUND (pin 3), makes device go IN.	BR	BR	LED 1

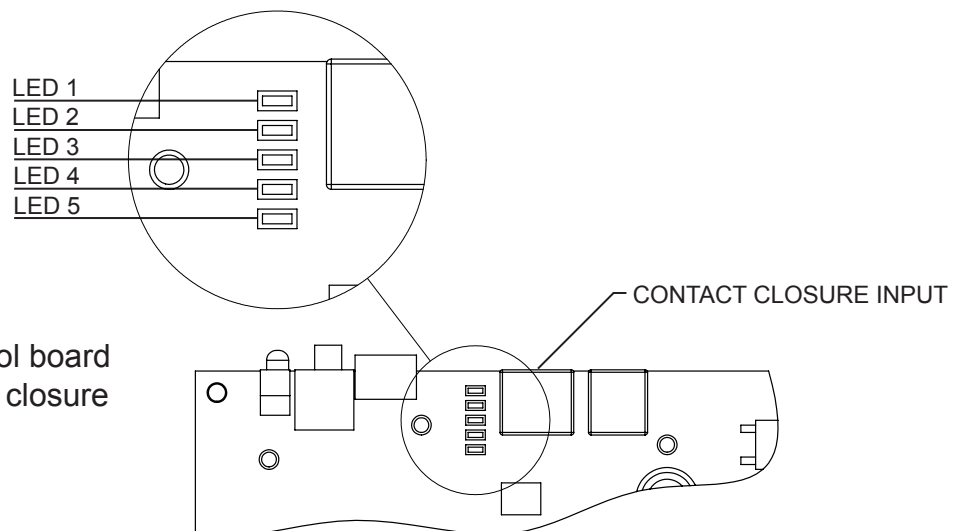

**NOTE:** Earlier versions of the control board may not have these contact closure LED indicators.

# SPS 800 / 1200 - Sliding Panel Mechanism with Screen Advance



## RS232

- Use an RJ25 connector in the socket marked RS232 on the control box to operate using RS232

**Pin 1: RX**  
**Pin 6 : TX**  
**Pin 3 & 4: GROUND**

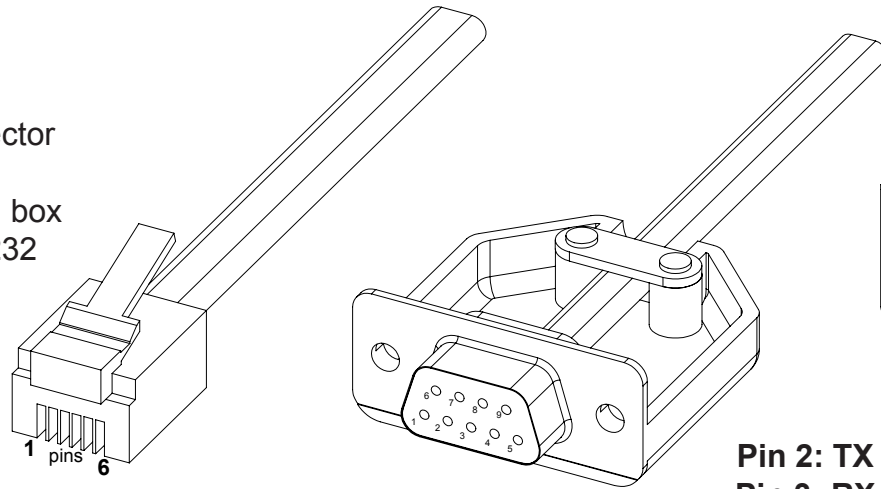

**Pin 2: TX**  
**Pin 3: RX**  
**Pin 5: GROUND**

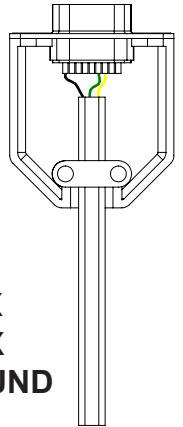

## Details

Baud rate: 9600  
 Stop bit: 1  
 Parity: None  
 Databits: 8

RJ25		9 PIN D
PIN 1: RX	TO	PIN 2: TX
PIN 6: TX	TO	PIN 3: RX
PIN 3: GROUND	TO	PIN 5: GROUND
PIN 4: GROUND	TO	PIN 5: GROUND



## IMPORTANT

Ensure protocol is entered exactly as written, including Carriage Return (Enter / ASCII 13).

Protocol	Action
fa_in Carriage Return (Enter ←↵)	Device IN
fa_out Carriage Return (Enter ←↵)	Device OUT
fa_stop Carriage Return (Enter ←↵)	Device STOP (At any position)

## Operation Details

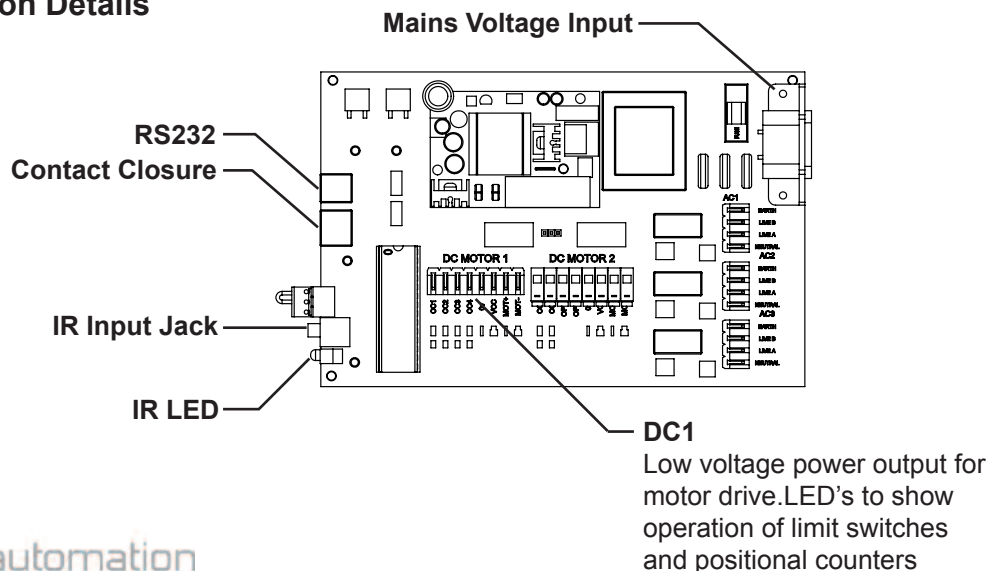

# SPS 800 / 1200 - Sliding Panel Mechanism with Screen Advance



## Operation buttons for the IR remote



### Note

Only buttons indicated are functional with the product. Any button pressed when in motion mechanism will stop.

**IN** - Screen moves back IN and panel moves down and out to fill space

**A** - Pulses the plasma advance mechanism in when entire mechanism is in OUT Position

**B** - Pulses the plasma advance mechanism OUT in order to gain access to rear screen in service mode

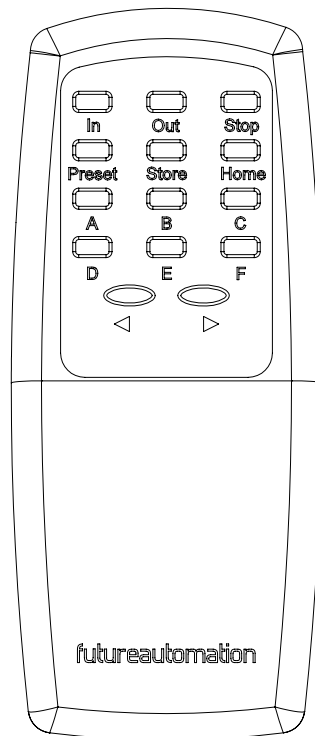

**OUT** - Panel moves in and up and screen moves OUT to fill space

**Stop** - Will stop the operation at any position

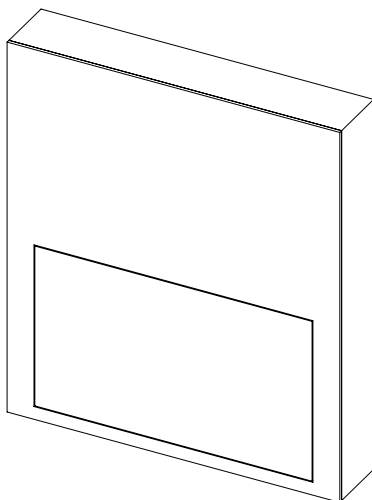

Panel Down

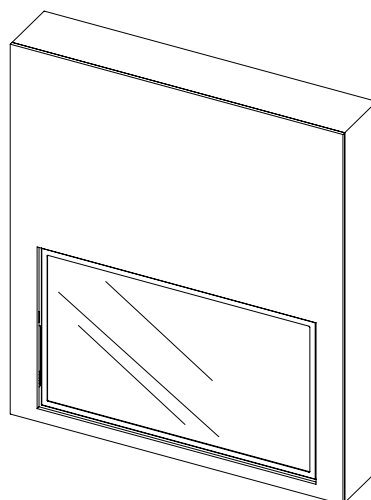

Screen Out

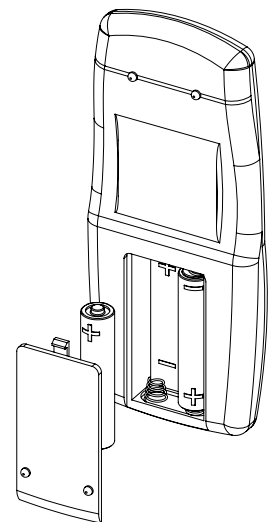

## Replacing batteries

### Future Automation IR Remote

Controller needs x2 AAA batteries which are provided within the packaging

# SPS 800 / 1200 - Sliding Panel Mechanism with Screen Advance



A general technical overview of the SPS 800 / 1200 Sliding Panel System.

		SPS 800	SPS 1200
<b>Mechanism Dimensions (W,H,D)</b>		Screen Width +270mm [10.6"]	Screen Width +270mm [10.6"]
		Screen Height x 2 +100mm [3.9"]	Screen Height x 2 +100mm [3.9"]
		Screen Depth +260 [10.2"]	Screen Depth +260 [10.2"]
<b>Mechanism Weight</b>	<b>SA</b>	75Kg [165.3lb]	85Kg [187.4lb]
	<b>SAH</b>	85Kg [187.4lb]	95Kg [209.4lb]
<b>Moving Panel MAX Weight</b>		15Kg [33.1lb]	15Kg [33.1lb]
<b>MAX Screen Height</b>		785mm [30.9"]	1185mm [46.6"]
<b>Screen Advance MAX Weight</b>	<b>SA</b>	50Kg [110lb]	50Kg [110lb]
	<b>SAH</b>	120Kg [265lb]	120Kg [265lb]
<b>Power Consumption</b>		Max 250W	Max 250W
<b>Power Consumption - On Standby</b>		3W	3W
<b>Standard Colour</b>		Black	Black
<b>Motor Kit Width</b>	<b>W1400</b>	Telescopic Width 880 - 1400mm [34.6 - 55.1"]	Telescopic Width 880 - 1400mm [34.6 - 55.1"]
	<b>W1700</b>	Telescopic Width 1200 - 1700mm [47.2 - 66"]	Telescopic Width 1200 - 1700mm [47.2 - 66"]
	<b>W2100</b>	Telescopic Width 1600 - 2100mm [63 - 82.5"]	Telescopic Width 1600 - 2100mm [63 - 82.5"]
<b>Control</b>		IR Remote, Contact Closure & RS232	IR Remote, Contact Closure & RS232
<b>Power Supply</b>		110V or 240V	110V or 240V
<b>Control Of 3rd Party Product</b>		No	No
<b>Control Box Size (W,D,H)</b>		150x410x52mm [5.9x16.1x2"]	150x410x52mm [5.9x16.1x2"]

## SPS 800 / 1200 - Sliding Panel System - Trouble shooting

For information on our products please refer to our web site - [www.futureautomation.co.uk](http://www.futureautomation.co.uk) or for questions on installations and our product range please phone us on - **+44(0) 1438 833577** and ask for our technical support department.



# SPS 800 / 1200 - Sliding Panel Mechanism with Screen Advance

---



**Notes...**



**Future Automation**

Unit 2 Kimpton Enterprise Park  
Claggy Road  
Kimpton  
Hertfordshire  
SG4 8HP  
United Kingdom

Tel: +44 (0) 1438 833 577

Fax: +44 (0) 1438 833 565

Email: [info@futureautomation.co.uk](mailto:info@futureautomation.co.uk)

[www.futureautomation.co.uk](http://www.futureautomation.co.uk)