

SOUND OUTPUT

Speaker type
2 x 6" woofer

Nominal impedance
4 Ω

Crossover
no crossover on board - DSP needed (HP 35 Hz 12dB/oct min; LP 120 Hz 12 dB/oct min)

Frequency range
38-150 Hz (-6dB)

Sensitivity (1W-1m)
90 dB

Speaker Max Power
600W

Speaker RMS Power
300W

Recommended amplifier power
500W (Class D)

SPECIFICATIONS

Material
composite material available in black or white

Mechanic material
stainless steel

Dimensions
1283 x 310 x 285 mm

Weight
11 kg

Unpacking: to remove the Shark from the shipping box carefully follow these steps

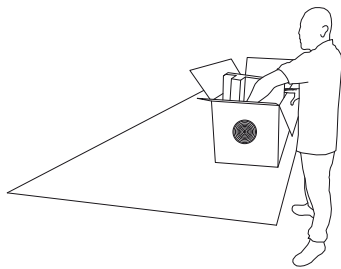

1.
Lay the box on a counter that makes unpacking comfortable and proceed to open the box.

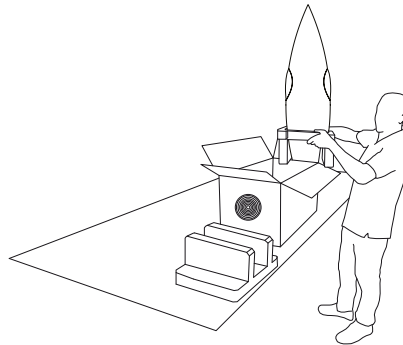

2.
Gently lift the module, which is firmly kept safe into the box by its packaging, and remove the molded foam.

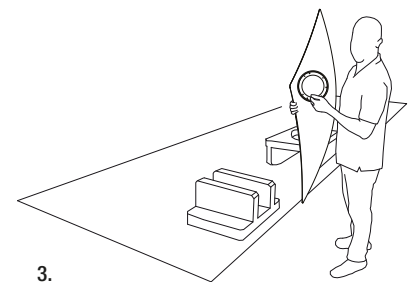

3.
Remove carefully the module from the protective plastic envelope and proceed to installation.

Installation: the Shark_Sub loudspeaker can be installed either indoor and outdoor, on wall, on ceiling or between tree branches; to fix the module use the appropriate mechanic and shown in the images. In the case you decide to use the metal tube fixing option, insert the steel tube into its seat connected to the ball joint till it stops, then block the tube tightening the two miniscrews, making sure to lock them into the proper holes on the tube. Proceed according to the different anchoring options like shown below.

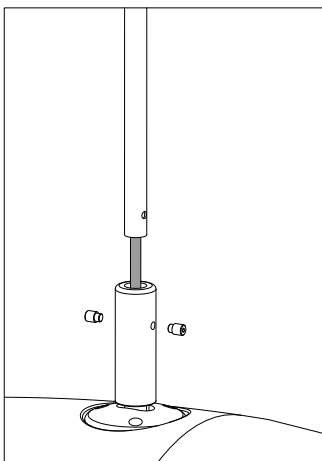

Connection to the body

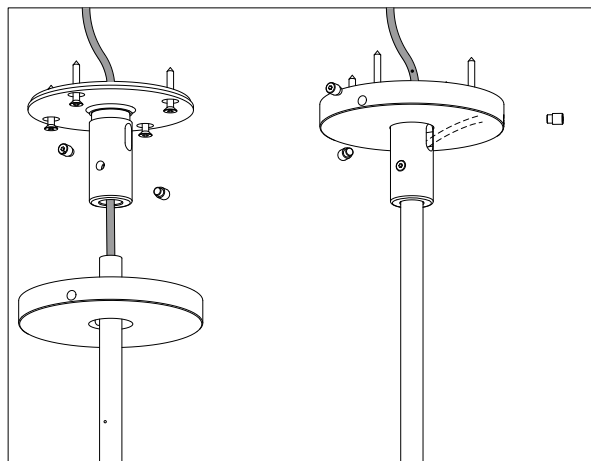

Connection to the ceiling - Indoor - (VPERG anchoring)

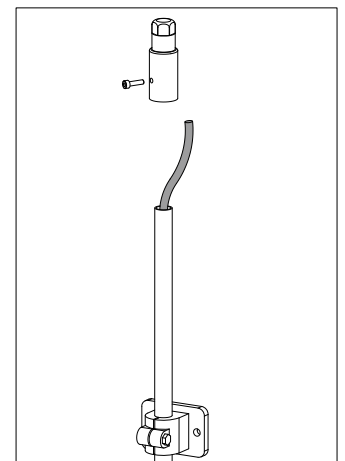

Connection to the wall
Indoor/Outdoor - (FK-12 clamp)

Modules intended to be mounted with steel cable between tree branches are delivered with the mechanic and cables already assembled, ready to be installed. The three divergent steel cables (ideally 120° apart from each other in plan) should be placed far apart as possible and fixed either around a branch or other supports (eyelet/eyebolt anchored to wall/structure) with a loop clamped with proper steel wire clamps.

It is recommended to use a soft plastic or rubber sleeve around the steel wire where it comes into contact with fragile surfaces such as the branches of a tree or painted rods.

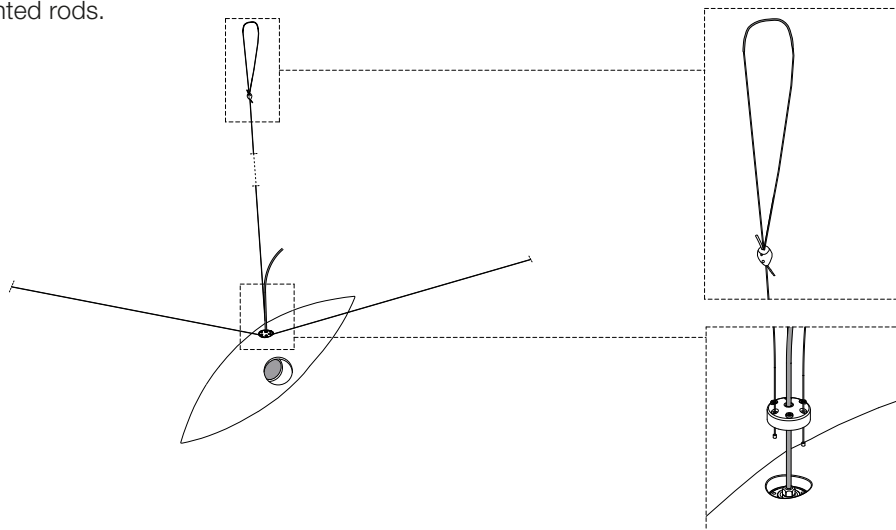

Diffusion and directionality: The Shark, unique in its kind, is a suspended subwoofer, in a “virtual vibrations free” symmetrical configuration: two perfectly balanced state-of-the-art 6" drivers symmetrically arranged within the body provide massive air movement and massive output virtually vibration free, because the opposing forces of equal magnitude effectively cancel each other.

Connection: connect the Shark directly to the amplifier through the chosen connectors.

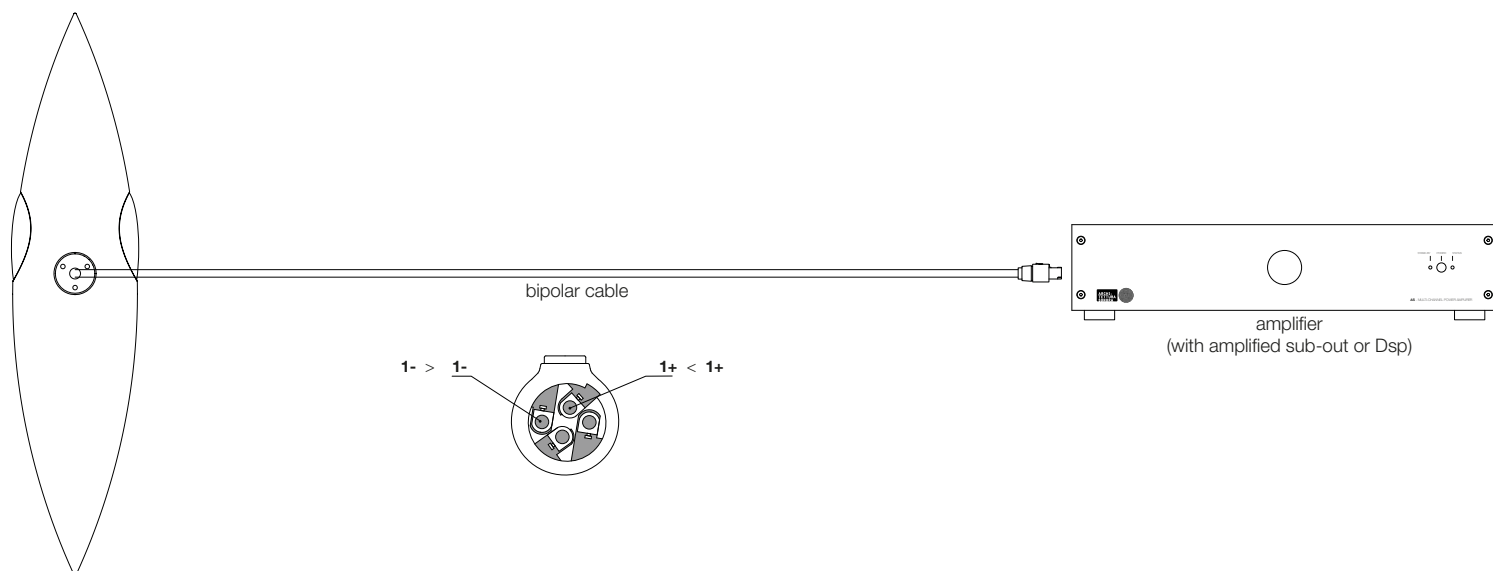

Maintenance and care: to keep your speakers beautiful as long as possible, we warmly recommend doing maintenance at least once a year. When not in use, sound modules should be appropriately covered or stored away; heavy duty protective covers are available from AS.

Please refer to the General Manual for appropriate instructions and note that any departure from our recommendations on care and cleaning, or any evidence of misuse or damages from ordinary wear and tear, will void all warranty claims.